

2008 Chevrolet Tahoe and GMC Yukon Two-Mode Hybrid

Seats and Restraint System	1-1	Driving Your Vehicle	4-1
Front Seats	1-2	Your Driving, the Road, and Your Vehicle	4-2
Restraint System Check	1-3	Towing	4-2
Features and Controls	2-1	Service and Appearance Care	5-1
Storage Areas	2-2	Service	5-2
Starting and Operating Your Vehicle	2-3	Checking Things Under the Hood	5-3
Instrument Panel	3-1	Bulb Replacement	5-21
Climate Controls	3-2	Electrical System	5-22
Warning Lights, Gages, and Indicators	3-3	Tires	5-24
Driver Information Center (DIC)	3-11	Capacities and Specifications	5-42
Audio System(s)	3-13	Maintenance Schedule	6-1
		Maintenance Schedule	6-2
		Index	1

Preface

GENERAL MOTORS, GM and the GM Emblem, CHEVROLET, the CHEVROLET Emblem, GMC, the GMC Emblem, and the names TAHOE and YUKON are registered trademarks of General Motors Corporation.

The information in this manual supplements the owner manual. This manual includes the latest information at the time it was printed. GM reserves the right to make changes after that time without further notice.

Keep this manual in the vehicle for quick reference.

Introduction

Your hybrid SUV is designed to be more fuel efficient than the standard SUV, which results in reduced carbon dioxide emissions.

Warranty Information

Two-Mode Hybrid Specific Warranty

This information supersedes the Hybrid Specific Warranty found in the Limited Warranty and Owner Assistance Information booklet furnished with your new vehicle.

For vehicles sold in the United States, in addition to the Bumper-to-Bumper Coverage described in the Limited Warranty and Owner Assistance manual, General Motors will warrant certain Hybrid components for each 2008 Chevrolet Tahoe Two-Mode Hybrid and GMC Yukon Two-Mode Hybrid (hereafter referred to as Hybrid) for 8 years or 100,000 miles (160 000 kilometres), whichever comes first, from the original in-service date of the vehicle, against warrantable repairs to the specific Hybrid components of the vehicle.

For vehicles sold in Canada, in addition to the Complete Vehicle Coverage described in the GM Canadian Limited Warranty, Maintenance and Owner Assistance booklet, General Motors of Canada Limited will warrant certain Hybrid components for each 2008 Chevrolet Tahoe Two-Mode Hybrid and GMC Yukon Two-Mode Hybrid (hereafter referred to as Hybrid) for 8 years, or 160,000 kilometres, whichever comes first, from the original in-service date of the vehicle, against warrantable repairs to the specific Hybrid components of the vehicle.

This warranty is for Hybrid vehicles registered in the United States or Canada, and normally operated in the United States or Canada. In addition to the initial owner of the vehicle, the coverage described in this Hybrid warranty is transferable at no cost to any subsequent person(s) who assumes ownership of the vehicle within the above described 8 years or 100,000 mile (160 000 kilometres) term. No deductibles are associated with this Hybrid warranty.

This Hybrid warranty is in addition to the express conditions and warranties described in the Limited Warranty and Owner Assistance manual. The coverage and benefits described under “New Vehicle Limited Warranty” are not extended or altered because of this special Hybrid Component Warranty.

For 2008 Hybrid owners requiring more comprehensive coverage than that provided under this Hybrid warranty, a GM Protection Plan may be available. See your dealer for more details.

What is Covered

This Hybrid warranty covers repairs to correct any vehicle defect related to materials or workmanship occurring during the 8 year or 100,000 miles (160 000 kilometres) term for the following:

Transmission

Automatic transmission components including the transmission auxiliary fluid pump, transmission auxiliary pump controller, and 3 phase transmission cables.

Brakes

Brake modulator.

Other Hybrid Components

Battery pack, 300v cables, Drive Motor/Generator Control Module (DMCM) and Accessory Power Module.

Towing

During the 8 year or 100,000 mile (160 000 kilometres) Hybrid warranty period, towing is covered to the nearest servicing dealer if your vehicle cannot be driven because of a warranted defect. Contact the Roadside Assistance Center for towing. Refer to the owner manual for details.

Roadside Assistance is not part of or included in the coverage provided by the new Vehicle Limited Warranty. General Motors and General Motors of Canada Limited reserve the right to make any changes or discontinue the Roadside Assistance program at any time without notification.

Courtesy Transportation

During the 8 year or 100,000 mile (160 000 kilometres) Hybrid warranty period, interim transportation is available under the Courtesy Transportation Program. Consult your dealer for details.

Courtesy Transportation is not a part of the New Vehicle Limited Warranty. The Limited Warranty and Owner Assistance Information booklet furnished with the vehicle provides detailed warranty coverage information.

General Motors reserves the right to unilaterally modify, change, or discontinue Courtesy Transportation at any time and to resolve all questions of claim eligibility pursuant to the terms and conditions described herein at its sole discretion.

What is Not Covered

In addition to the “What is Not Covered” section of the warranty booklet, this Hybrid warranty does not cover the following items:

Wear Items

Wear items, such as brake linings, are not covered in this Hybrid warranty.

Maintenance

As the vehicle owner, you are responsible for the performance of the scheduled maintenance listed in your owner manual. Maintenance intervals, checks, inspections, and recommended fluids and lubricants as prescribed in the owner manual are necessary to keep your vehicle in good working condition. Any damage caused by owner/lessee failure to follow scheduled maintenance may not be covered by warranty. Scheduled maintenance includes such items as:

- Brake Pads/Linings
- Coolants and Fluids
- Filters

Using this Supplement

This supplement contains information specific to the hybrid components of the vehicle. It does not explain everything you need to know about the vehicle. Read this supplement along with the owner manual to learn about the vehicle’s features and controls.

Index

A good place to look for what you need is the Index in back of this supplement. It is an alphabetical list of what is in the supplement, and the page number where you will find it.

Section 1 Seats and Restraint System

Front Seats	1-2	Restraint System Check	1-3
Power Seats	1-2	Replacing Restraint System Parts After a	
Manual Lumbar	1-2	Crash	1-3
Manual Reclining Seatback	1-2		

Front Seats

Power Seats

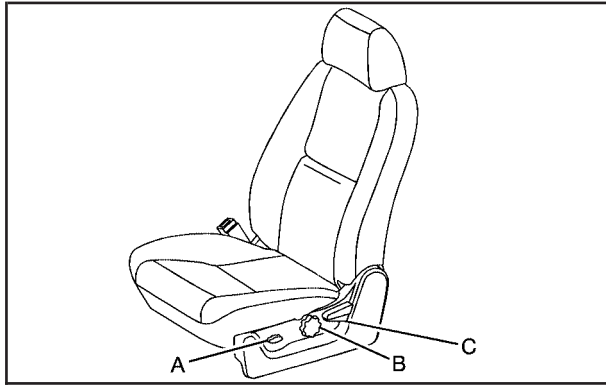

- A. Power Seat Adjustment Control
- B. Manual Lumbar Control
- C. Manual Reclining Seatback Lever

Adjust the seat forward or rearward by sliding the control (A) forward or rearward.

Your vehicle may have additional features to adjust your vehicle's power seat:

- Raise or lower the front part of the seat cushion by moving the front of the control up or down.
- Raise or lower the entire seat by moving the entire control up or down.

Manual Lumbar

Increase or decrease lumbar support by turning the control (B) forward or rearward.

Manual Reclining Seatback

To recline the seatback:

1. Lift the reclining seatback lever (C).
2. Move the seatback to the desired position, then release the lever to lock the seatback in place
3. Push and pull on the seatback to make sure it is locked.

To return the seatback to an upright position:

1. Lift the lever fully without applying pressure to the seatback and the seatback will return to the upright position.
2. Release the lever to lock the seatback in place.
3. Push and pull on the seatback to make sure it is locked.

Restraint System Check

Replacing Restraint System Parts After a Crash

If an airbag inflates or the vehicle has been in a crash, the vehicle's sensing system may command the automatic hybrid battery disconnect to open. The battery will disconnect. The hybrid battery will be off and the vehicle will not start. The airbag readiness light and/or SERVICE HYBRID SYSTEM message may come on in the driver information center. See "Airbag Readiness Light" in the owner manual and *Driver Information Center (DIC)* on page 3-11 for more information.

To operate the vehicle, the automatic hybrid battery disconnect must be reconnected by a qualified service technician and sensing system parts will need to be replaced. Have the vehicle serviced right away.

Section 2 Features and Controls

Storage Areas	2-2	Regenerative Braking	2-9
Power Outlet Alternating Current	2-2	Running the Vehicle While Parked	2-10
Starting and Operating Your Vehicle	2-3		
Starting Your Vehicle	2-3		
Automatic Transmission Operation	2-6		

Storage Areas

Power Outlet Alternating Current

Your vehicle may have a power outlet that can be used to plug in electrical equipment that uses a maximum limit of 150 watts.

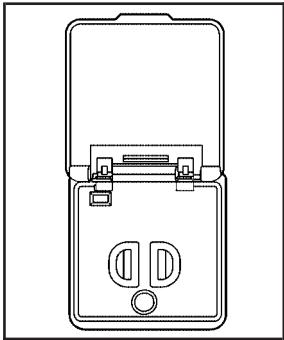

The power outlet is located in the rear cargo area on the driver side.

An indicator light on the outlet turns on to show it is in use. The light comes on when the ignition is in ON/RUN and equipment requiring less than 150 watts is plugged into the outlet, and no system fault is detected.

The indicator light does not come on when the ignition is in LOCK/OFF or if no equipment is plugged into the outlet.

If you try to connect equipment using more than 150 watts or a system fault is detected, a protection circuit shuts off the power supply and the indicator light turns off. To reset the circuit, unplug the item and plug it back in or turn the Retained Accessory Power (RAP) off and then back on. The power restarts when equipment using 150 watts or less is plugged into the outlet and a system fault is not detected.

The power outlet is not designed for the following electrical equipment and may not work properly if these items are plugged into the power outlet:

- Equipment with high initial peak wattage such as: compressor-driven refrigerators and electric power tools.
- Other equipment requiring an extremely stable power supply such as: microcomputer-controlled electric blankets, touch sensor lamps, etc.

See *High Voltage Devices and Wiring* on page 5-3.

Starting and Operating Your Vehicle

Starting Your Vehicle

CAUTION:

Exiting your vehicle, without first shifting into PARK (P), may cause the vehicle to move, and you or others can be seriously injured.

CAUTION: (Continued)

CAUTION: (Continued)

Because your vehicle has the Automatic Engine Start/Stop feature, the vehicle's engine might seem to be shut off when you come to a complete stop. However, once the brake pedal is released, the vehicle can move. The vehicle's engine can also restart at any time.

Shift to PARK (P) and turn the ignition to LOCK/OFF, before exiting the vehicle.

Start the engine as you would any other engine. See "Starting Your Engine" in the owner manual for more information on starting. The hybrid system provides very quiet engine starting. If pulling a trailer with trailer brakes, see *Towing a Trailer on page 4-2* for more information.

Auto Stop

The vehicle has an Auto Stop feature. After a successful engine start, the Hybrid Powertrain Control Module (HPCM) may turn off the engine and operate in the Auto Stop mode. Some of the vehicle conditions that allow the engine to stop running and enter the Auto Stop mode are:

- Ignition switch is in the ON/RUN position.
- The hood is closed.
- The gear selector is in PARK (P), NEUTRAL (N) or DRIVE (D).
- The hybrid battery is at an acceptable state of charge.
- The hybrid battery voltage, temperature or power limits are not exceeded. In very hot conditions, Auto Stop may be unavailable until the hybrid battery has cooled.
- The engine is at operating temperature.

If you are on an incline, the hybrid drive motor can help keep your vehicle from rolling backwards, even if the engine is in Auto Stop.

With your foot off the brake and the vehicle on level ground, the hybrid drive motor may cause your vehicle to roll slowly forward, even when the engine is in Auto Stop.

To be sure your vehicle will not move or roll, always keep your foot firmly on the brake pedal until you are ready for the vehicle to move.

Engine OFF and AUTO STOP modes are indicated on the tachometer display. When the tachometer needle indicates OFF, the engine is not running and will remain off until the ignition key is placed in the START position or a remote vehicle start is performed. When the tachometer needle indicates AUTO STOP, the engine is not running but may Auto Start at any time without notice. See *Tachometer on page 3-4* for more information.

A chime will sound if the driver door is opened while in Auto Stop as a reminder that the ignition switch is not in the LOCK/OFF position. Always turn the ignition switch to LOCK/OFF and remove the key from the ignition switch when exiting the vehicle.

Auto Start

The vehicle also has an Auto Start feature. The engine will remain off while in Auto Stop mode until vehicle conditions require the engine to run. The near-instant starting of the engine from Auto Stop mode is called Auto Start. Some of the vehicle conditions that may cause the HPCM to Auto Start the engine are:

- The hood is opened.
- The gear selector is in MANUAL MODE (M) or REVERSE (R).
- The hybrid battery state of charge is too low.
- The hybrid battery voltage, temperature or power limits are exceeded.
- The engine is not at operating temperature.
- Acceleration demands require the use of the engine.

EV Mode

The vehicle also has an EV mode which uses only the electric motor to move the vehicle. Depending on the state of battery charge, the vehicle can travel up to two miles in EV mode. EV mode is unavailable when the vehicle is out of fuel.

While lightly accelerating, the vehicle will be propelled in EV mode.

If increased acceleration is required, or the vehicle achieves a speed of approximately 25 mph (40 km/h), the engine will start automatically. The engine will shut off at speeds below 25 MPH (40 km/h) unless the transmission is in MANUAL MODE (M) or Auto Stop is disabled.

During heavy acceleration, both the engine and hybrid electric motors supply power. A sensation similar to a transmission gear change can be felt as the transmission changes modes. Engine RPM may remain above 4,000 RPM for a longer period during hard acceleration.

Automatic Transmission Operation

Your vehicle has an M99–EVT transmission, and has an electronic shift position indicator within the instrument panel cluster. The electronic shift position indicator displays when the shift lever is moved out of PARK (P).

There are several different positions for the shift lever.

P R N D M

See “Range Selection Mode” later in this section.

PARK (P): This position locks the rear wheels. It is the best position to use when you start your engine because the vehicle cannot move easily.

When parked on a hill, especially when the vehicle has a heavy load, you may notice an increase in the effort to shift out of PARK (P). See “Shifting Into PARK (P)” in the Index of vehicle’s owner manual for more information.

CAUTION:

It is dangerous to get out of your vehicle if the shift lever is not fully in PARK (P) with the parking brake firmly set. Your vehicle can roll.

Do not leave your vehicle when the engine is running unless you have to. If you have left the engine running, the vehicle can move suddenly. You or others could be injured. To be sure your vehicle will not move, even when you are on fairly level ground, always set your parking brake and move the shift lever to PARK (P). See “Shifting Into Park (P)” in the Owner Manual.

If you are pulling a trailer, see *Towing a Trailer* on page 4-2.

REVERSE (R): Use this gear to back up.

Notice: Shifting to REVERSE (R) while your vehicle is moving forward could damage the transmission. The repairs would not be covered by your warranty. Shift to REVERSE (R) only after your vehicle is stopped.

To rock your vehicle back and forth to get out of snow, ice, or sand without damaging the transmission, see “If Your Vehicle is Stuck in Sand, Mud, Ice, or Snow” in the Index of the vehicle’s owner manual.

NEUTRAL (N): In this position, the engine and transmission are not connected with the wheels. To restart while the vehicle is already moving, use NEUTRAL (N) only.

 **CAUTION:**

Shifting into a drive gear while the engine is running at high speed is dangerous. Unless your foot is firmly on the brake pedal, your vehicle could move very rapidly. You could lose control and hit people or objects. Do not shift into a drive gear while your engine is running at high speed.

Notice: Shifting out of PARK (P) or NEUTRAL (N) with the engine running at high speed may damage the transmission. The repairs would not be covered by your warranty. Be sure the engine is not running at high speed when shifting your vehicle.

DRIVE (D): This position is for normal driving. It provides the best fuel economy for your vehicle. If you need more power for passing, and you are:

- Going less than about 35 mph (55 km/h), push the accelerator pedal about halfway down.
- Going about 35 mph (55 km/h) or more, push the accelerator all the way down.

DRIVE (D) can be used when towing a trailer, carrying a heavy load, driving on steep hills, or for off-road driving. You may want to shift the transmission to a lower gear selection if the transmission shifts too often.

Downshifting the transmission in slippery road conditions could result in skidding, see “Skidding” under “Loss of Control” in the Index of the vehicle’s owner manual.

When temperatures are very cold, the transmission’s gear shifting may be delayed providing more stable shifts until the engine warms up. Shifts may be more noticeable with a cold transmission. This difference in shifting is normal.

MANUAL MODE (M): This position lets drivers select the range of gears appropriate for current driving conditions. If your vehicle has this feature, see “Range Selection Mode” later in this section.

Notice: Spinning the tires or holding the vehicle in one place on a hill using only the accelerator pedal may damage the transmission. The repair will not be covered by your warranty. If you are stuck, do not spin the tires. When stopping on a hill, use the brakes to hold the vehicle in place.

Your vehicle has a shift stabilization feature that adjusts the transmission shifting to the current driving conditions in order to reduce rapid upshifts and downshifts. This shift stabilization feature is designed to determine, before making an upshift, if the engine will be able to maintain vehicle speed by analyzing things such as throttle position, vehicle load, and hill grade. If the shift stabilization feature determines that a current vehicle speed cannot be maintained, the transmission does not upshift and instead holds the current gear. In some cases, this may appear to be a delayed shift, however the transmission is operating normally.

Range Selection Mode

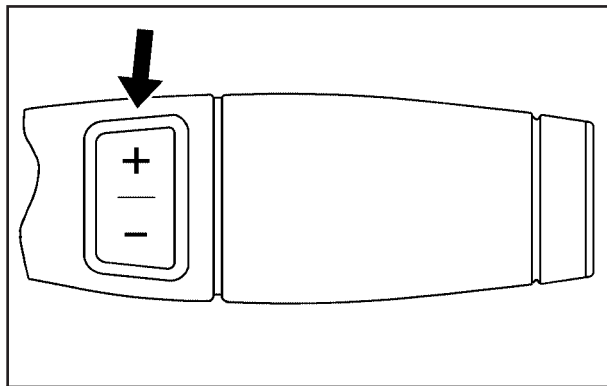

The Range Selection Mode controls the vehicle's transmission.

To use this feature, do the following:

1. Move the shift lever to the MANUAL MODE (M).
2. Press the plus/minus button, to upshift or downshift selecting the desired range of gears for your current driving conditions.

While in the MANUAL MODE (M) a number displays next to the M, indicating the current gear that has been selected. The number displayed in the gear indicator is the highest gear that can be used. However, your vehicle can automatically shift to lower gears as it adjusts to driving conditions. This means that all gears below that number are available. When THIRD (3) is selected, FIRST (1) through THIRD (3) gears are automatically shifted by the vehicle, but FOURTH (4) cannot be used until the plus/minus button located on the steering column lever is used to change to the gear.

The Range Selection Mode controls the vehicle and engine speed while driving down a hill or towing a trailer, by allowing you to select a desired range of gears.

When you move the shift lever into M, the transmission will default to M4. In this gear range, effective engine braking will occur at speeds above 45 mph (72 km/h).

Pushing the minus (–) button on the shift lever will change the gear range to M3. In this gear range, effective engine braking will occur at speeds above 35 mph (56 km/h).

Pushing the minus (–) button on the shift lever will change the gear range to M2. In this gear range, effective engine braking will occur at speeds above 25 mph (40 km/h).

Pushing the minus (–) button on the shift lever will change the gear range to M1. In this gear range, effective engine braking will occur at speeds above 10 mph (16km/h).

When operating in MANUAL MODE (M), Auto Stop is disabled. Vehicle efficiency is decreased operating in MANUAL MODE (M) compared to DRIVE (D).

Cruise control can be used while using the Range Selection Mode.

Regenerative Braking

Your vehicle uses a hybrid technology known as regenerative braking. This technology enables the electric drive motor on your vehicle to operate as a generator when you are coasting or braking. The energy of the moving vehicle is used to recharge the vehicle's high voltage hybrid battery.

The conventional hydraulic disc brakes on your vehicle work in partnership with the regenerative braking to insure effective braking in all situations, such as when the high voltage hybrid battery is fully charged or a high braking demand is requested. Four wheel, four channel ABS allows the vehicle to maintain steering control during braking and Electronic Stability Control (ESC) helps you to keep your vehicle in control in unfavorable conditions. These systems, however, are not a substitute for safe driving practices.

The braking system is computer controlled and uses the information provided by the driver's input at the brake pedal to seamlessly blend the regenerative braking with the conventional hydraulic disc brakes to meet any requirements for deceleration. The brake controller in your vehicle has a high pressure accumulator to provide the hydraulic pressure to the disc brakes in response to the driver's input. The controller interprets the braking request and uses regenerative braking, conventional hydraulic braking or a combination of both as necessary. Since the controller applies the hydraulic brakes through its high pressure accumulator, you may occasionally hear the motor driven pump in the controller when it runs to recharge the system. This recharging cycle is normal.

Even though the conventional disc brakes are operated by the controller, there is still a direct mechanical connection with the brake pedal and the hydraulic brake system in the unlikely event of a controller problem. See "Warning Lights, Gages, and Indicators" and "Driver Information Center (DIC)" in the Index of the vehicle's owner manual. In the event of a controller problem, your brake pedal may be harder to push and the stopping distance may be longer.

Running the Vehicle While Parked

It is better not to park with the engine running. But if you ever have to, here are some things to know.

CAUTION:

Exiting your vehicle, without first shifting into PARK (P), may cause the vehicle to move, and you or others can be seriously injured. Because your vehicle has the Automatic Engine Start/Stop feature, the vehicle's engine might seem to be shut off when you come to a complete stop. However, once the brake pedal is released, the vehicle can move. The vehicle's engine can also restart at any time.

Shift to PARK (P) and turn the ignition to LOCK/OFF, before exiting the vehicle.

Follow the proper steps to be sure your vehicle will not move. See "Shifting Into PARK (P)" in the owner manual for more information.

If you are pulling a trailer, see *Towing a Trailer on page 4-2* for more information.

Section 3 Instrument Panel

Climate Controls	3-2	Engine Coolant Temperature Gage	3-7
Warning Lights, Gages, and Indicators	3-3	Oil Pressure Gage	3-8
Instrument Panel Cluster	3-3	Oil Pressure Light	3-9
Tachometer	3-4	Fuel Gage	3-10
Charging System Light	3-4	Driver Information Center (DIC)	3-11
Fuel Economy Gage	3-5	DIC Warnings and Messages	3-11
Brake System Warning Light	3-5	Audio System(s)	3-13
Anti-lock Brake System (ABS) Warning Light	3-6	Navigation/Radio System	3-13
StabiliTrak [®] Indicator Light	3-7		

Climate Controls

For more information on the vehicle's climate control system, see "Climate Control System" in the owner manual Index.

Electric Air Conditioning Compressor

This hybrid vehicle has a 300 volt, electrically powered air conditioning compressor. This allows for continuous air conditioning operation and passenger comfort, even while the hybrid engine cycles on and off.

When operating the climate control system, select the AUTO mode and the desired temperature setting. The climate control system will automatically adjust the fan speed and airflow direction. The climate control system continues to adjust the climate control settings chosen for best use of electrical power.

To get maximum engine off time, select a warmer temperature setting or turn off the air conditioning to shut off the compressor. Continuous air conditioning use can cause the engine to autostart more frequently.

Some noise may be heard occasionally from the compressor, especially when air conditioning use is high and the engine has turned off.

Warning Lights, Gages, and Indicators

Instrument Panel Cluster

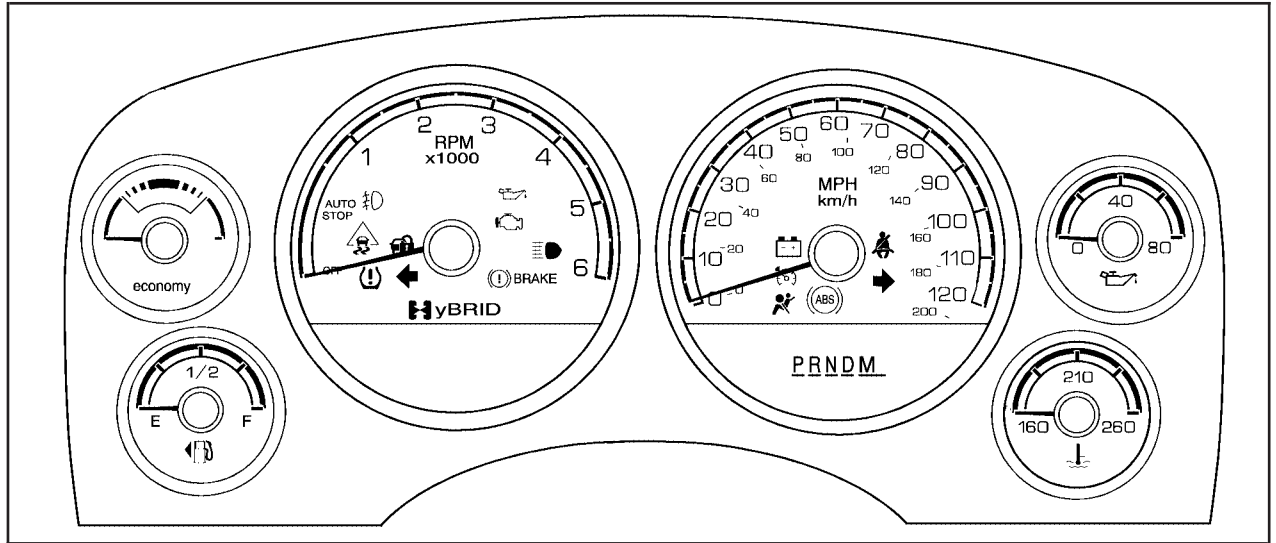

United States version shown, Canada similar

The instrument cluster is designed to let you know at a glance how your vehicle is running. You will know how fast you are going, about how much fuel you have, and many other things you will need to know to drive safely and economically.

Tachometer

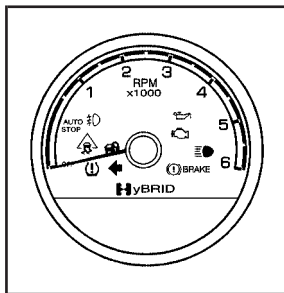

United States version shown, Canada similar

When the gas engine is off and the key is in the ON/RUN position, the tachometer indicates the state of the vehicle:

- AUTO STOP position indicates that the vehicle is still able to move and the engine could restart, by an Auto Start, at any time.
- OFF position indicates that either the vehicle was turned off or the engine has stalled.

When the engine is on, the Tachometer indicates the engine's revolutions per minute.

Charging System Light

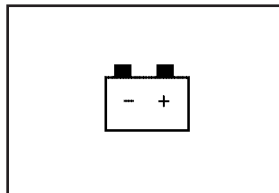

This light will come on briefly when you turn on the ignition to ACC/ACCESSORY or ON/RUN, but the engine is not running, as a check to show you it is working.

It should go out once the engine has been started. If it stays on, or comes on while driving, there could be a problem with the charging system. A charging system Driver Information Center (DIC) message may also appear. See *DIC Warnings and Messages on page 3-11* for more information. This light could indicate that there are electrical problems. Have it checked right away. If you must drive a short distance with the light on, be certain to turn off all the accessories, such as the radio and air conditioner.

Fuel Economy Gage

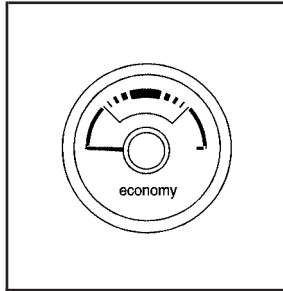

United States

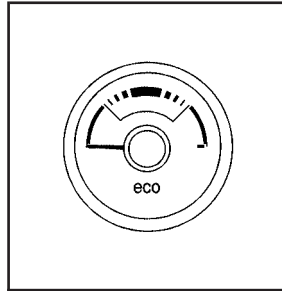

Canada

This gage shows when the vehicle is operating at a fuel efficient point.

By modifying your driving behavior to increase the economy time during driving, your fuel mileage will be improved. When driving in a way that increases the fuel economy, the indicator moves into the high efficiency band. When driving in a way that decreases fuel economy, the indicator moves into the less efficient band. There are several zones on the gage, indicating several levels of efficiency when accelerating or decelerating.

Brake System Warning Light

With the ignition in ON/RUN, the brake system warning light will come on when you set the parking brake. If you try to drive with the parking brake engaged, a chime will sound when the vehicle speed is greater than 5 mph (8 km/h).

Your vehicle's hydraulic brake system is divided into two parts. If one part is not working, the other part can still work and stop you. For good braking, though, you need both parts working well.

If the warning light comes on and a chime sounds there could be a brake problem. Have your brake system inspected right away.

This light may also come on due to low brake fluid. See your owners manual for more information.



United States

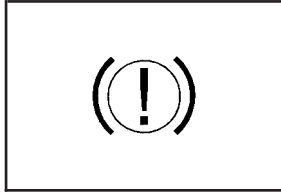

Canada

This light should come on briefly when you turn the ignition key to ON/RUN. If it does not come on then, have it fixed so it will be ready to warn you if there is a problem.

CAUTION:

Your brake system may not be working properly if the brake system warning light is on. Driving with the brake system warning light on can lead to an accident. If the light is still on after you have pulled off the road and stopped carefully, have the vehicle towed for service.

If the light comes on while you are driving, pull off the road and stop carefully. You may notice that the pedal is harder to push or may go closer to the floor. It may take longer to stop. If the light is still on, have the vehicle towed for service. See *Towing Your Vehicle on page 4-2*.

Anti-lock Brake System (ABS) Warning Light

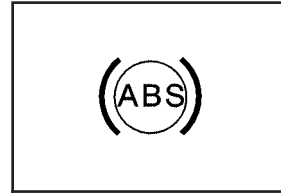

For vehicles with the Antilock Brake System (ABS), this light comes on briefly when the engine is in ON/RUN.

That is normal. If the light does not come on then, have it fixed so it will be ready to warn you if there is a problem.

If the ABS light stays on, turn the ignition off, if the light comes on when you are driving, stop as soon as it is safely possible and turn the ignition off. Then start the engine again to reset the system. If the ABS light still stays on, or comes on again while you are driving, your vehicle needs service. If the regular brake system warning light is not on, your vehicle still has brakes, but not antilock brakes.

If the regular brake system warning light is also on, your vehicle does not have antilock brakes and there is a problem with the regular brakes. See *Brake System Warning Light* on page 3-5.

For vehicles with a Driver Information Center (DIC), see *DIC Warnings and Messages* on page 3-11 for all brake related DIC messages.

StabiliTrak[®] Indicator Light



If the vehicle has StabiliTrak[®] this warning light should come on briefly when the ignition is in ON/RUN.

If the warning light does not come on then, have it fixed so it will be ready to warn you if there is a problem.

When this warning light flashes, the system is on. Driving should be adjusted accordingly.

If it stays on when while driving, there may be a problem with the StabiliTrak[®] system and the vehicle may need service.

Engine Coolant Temperature Gage

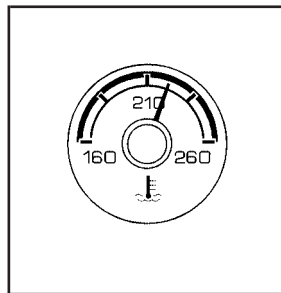

United States

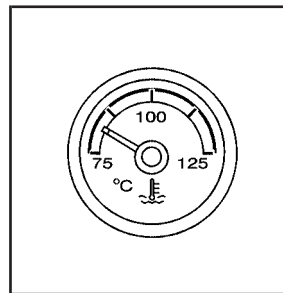

Canada

This gage shows the engine coolant temperature.

It also provides an indicator of how hard your vehicle is working. During a majority of the operation, the gage will read 210°F (100°C) or less. If you are pulling a load or going up hills, it is normal for the temperature to fluctuate and go over the 235°F (113°C) mark. However, if the gage reaches the 260°F (125°C) mark, it indicates that the cooling system is working beyond its capacity.

Oil Pressure Gage

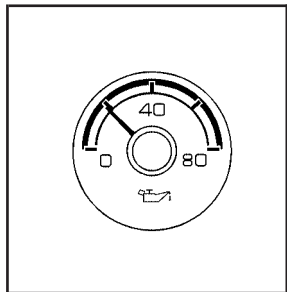

United States

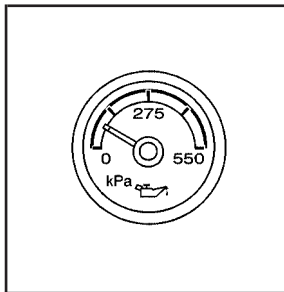

Canada

The oil pressure gage shows the engine oil pressure in psi (pounds per square inch) when the engine is running. Canadian vehicles indicate pressure in kPa (kilopascals).

Oil pressure should be 29 to 80 psi (200 to 550 kPa). In certain situations, such as long extended idles on hot days, it could read as low as 15 psi (105 kPa) and still be considered normal.

A reading in the low pressure zone may be caused by a dangerously low oil level or some other problem causing low oil pressure. Check your oil as soon as possible.

CAUTION:

Do not keep driving if the oil pressure is low. If you do, your engine can become so hot that it catches fire. You or others could be burned. Check your oil as soon as possible and have your vehicle serviced.

Notice: Lack of proper engine oil maintenance may damage the engine. The repairs would not be covered by your warranty. Always follow the maintenance schedule in this manual for changing engine oil.

AUTO STOP

When the engine goes into Automatic Engine Stop, the oil pressure gage will drop to zero when the tachometer is at the AUTO STOP position. This is normal and oil pressure will return to normal operating range once the engine starts.

See *Starting Your Vehicle* on page 2-3 for more information.

AUTO STOP will display in the Driver Information Center (DIC) when the vehicle speed is zero. See *DIC Warnings and Messages* on page 3-11 for more information.

Oil Pressure Light

CAUTION:

Do not keep driving if the oil pressure is low. If you do, your engine can become so hot that it catches fire. You or others could be burned. Check your oil as soon as possible and have your vehicle serviced.

Notice: Lack of proper engine oil maintenance may damage the engine. The repairs would not be covered by your warranty. Always follow the maintenance schedule in this manual for changing engine oil.

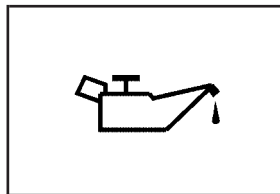

This light will come on briefly as a check to be sure it works, when the ignition is in ON/RUN. If it does not, have your vehicle serviced.

If the light comes on and stays on, it means that oil is not flowing through your engine properly. You could be low on oil and you might have some other system problem.

During an AUTO STOP there is zero oil pressure, but this light will not come on.

Fuel Gage

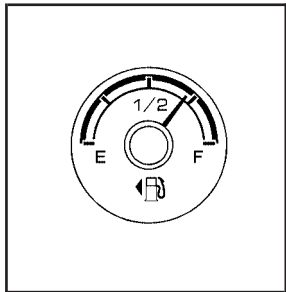

United States

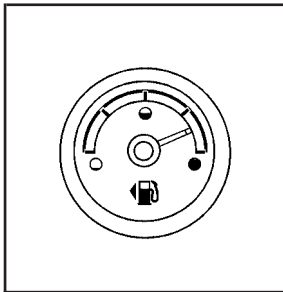

Canada

When the ignition is on, the fuel gage shows you approximately how much fuel you have left in your tank. The gage will first indicate E (empty) before you are out of fuel, but you should get more fuel as soon as possible.

Listed are four situations you may experience with your fuel gage:

- At the gas station, the fuel pump shuts off before the gage reads F (full).
- It takes a little more or less fuel to fill up than the fuel gage indicated. For example, the gage may have indicated the tank was half full, but it actually took a little more or less than half the tank's capacity to fill the tank.
- The gage moves a little when you turn a corner or speed up.
- The gage doesn't go back to E (empty) when you turn off the ignition.

None of these indicate a problem with the fuel gage.

Driver Information Center (DIC)

Trip/Fuel Menu Items

Press the trip/fuel button to display the battery voltage. For more items see “DIC Operation and Displays” in the owner manual.

BATTERY VOLTAGE

This display shows the current battery voltage. If the voltage is in the normal range, the value will display. For example, the display may read BATTERY VOLTAGE 13.2 VOLTS. If the voltage is low, the display will show LOW. If the voltage is high, the display will show HIGH. Your vehicle’s charging system regulates voltage based on the state of the battery. The battery voltage may fluctuate when viewing this information on the DIC. This is normal. See “Charging System Light” in the owner manual for more information. If there is a problem with the battery charging system, the DIC will display a message. See *DIC Warnings and Messages on page 3-11*.

INST (Instantaneous) ECONOMY

This display normally shows instantaneous fuel economy. When the vehicle is in Auto Stop mode AUTO STOP will be displayed. See *Starting Your Vehicle on page 2-3* for more information.

DIC Warnings and Messages

Warning messages are displayed on the DIC to notify the driver that the status of the vehicle has changed and that some action may be needed by the driver to correct the condition. If there is more than one message that needs to be displayed they will appear one after another. Some messages may not require immediate action but you should press the select button or the trip odometer reset stem on the instrument panel cluster to acknowledge that you received the message and clear it from the display. Some messages cannot be cleared from the display because they are more urgent; these messages require action before they can be removed from the DIC display. The following are the possible messages that can be displayed and some information about them. For information on other DIC messages, see “DIC Warnings and Messages” in the owner manual Index.

BATTERY NOT CHARGING

If the hybrid battery system faults or fails this message will appear on the DIC. The engine auto stop feature will be disabled and the battery/charging system light will appear in the instrument panel cluster. See “Battery Warning Light” in the owner manual Index.

Driving with this light on could drain your batteries. Have the electrical system checked as soon as possible. Pressing the select button or the trip odometer reset stem on the instrument panel cluster will acknowledge this message and clear it from the DIC display.

HOOD OPEN

If the hood is not fully closed or there is a problem with the hood switch, this message will be displayed. Close the hood to clear the message. If the Hood Open DIC message continues to be displayed after verifying the hood is closed, you should have the hood switch serviced. Pressing the select button or the trip stem on the instrument panel cluster will acknowledge this message and clear it from the DIC display.

When this message is displayed, the auto stop function will not operate. If the vehicle is in auto stop mode when this message appears, the engine will instantly start. See *Starting Your Vehicle on page 2-3*.

OIL PRESSURE LOW STOP ENGINE

If engine oil pressure is low, this message will be displayed on the DIC. Stop the vehicle as soon as safely possible and do not operate it until the cause of the low oil pressure has been corrected. Check your oil level as soon as possible and have your vehicle serviced. See “Engine Oil” in the owner manual Index.

SERVICE BRAKE SYSTEM

This message will be displayed if there is a problem with the brake system. You will still be able to brake, but it will be noticeably more difficult. Pull off the road to a safe location and have your vehicle towed to the nearest dealer/retailer for service. See “Brakes,” “Brake System Warning Light,” and “ABS Brake System Warning Light” in the owner manual Index.

SERVICE HYBRID SYSTEM

If this message is displayed on the DIC, the vehicle may continue to operate, but you need to have it serviced as soon as possible.

SERVICE POWER STEERING

This message displays if a problem has been detected with the electric power steering. Have your vehicle serviced by your dealer/retailer immediately.

Audio System(s)

Navigation/Radio System

The vehicle has a navigation radio system. See the Navigation System manual for more information.

The navigation system has built-in features intended to minimize driver distraction. Technology alone, no matter how advanced, can never replace your own judgment. See the Navigation System manual for tips to help reduce distractions while driving.

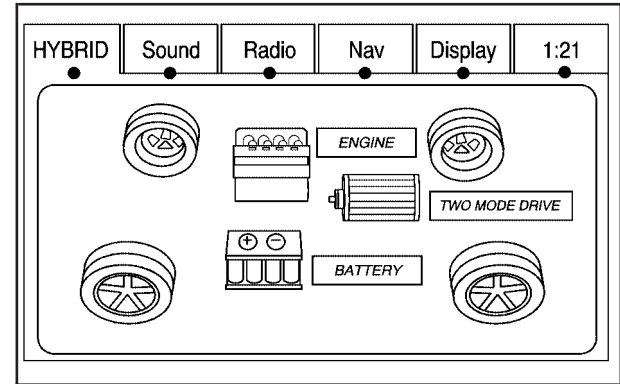

To view the hybrid screen, press the MENU button on the radio. The hybrid screen displays when entering the Configuration Menu.

The display shows:

- Auto Stop
- Battery Charging
- Engine Idle
- 2-Wheel and 4-Wheel Drive Modes for:
 - Engine Power
 - Battery Power
 - Hybrid Power

Section 4 Driving Your Vehicle

Your Driving, the Road, and Your Vehicle	4-2	Towing	4-2
Electric Power Steering	4-2	Towing Your Vehicle	4-2
		Recreational Vehicle Towing	4-2
		Towing a Trailer	4-2

Your Driving, the Road, and Your Vehicle

Electric Power Steering

Your vehicle is equipped with On-Demand Electric-Assist Power Steering instead of conventional full-time hydraulic power steering. It uses electricity supplied by the same battery which is re-charged by the regenerative braking system.

There are many advantages to electric power steering. Because the system is On-Demand Electric-Assist, energy is used only when you turn the steering wheel, or when the steering gear is used to help isolate the forces of rough roads. This system does not use power steering fluid, making it maintenance-free. The steering system has been calibrated to provide optimal performance and feel at all operating speeds and at any load.

There is an electric motor attached to the rack-and-pinion steering gear. When you first turn the steering wheel, the steering controller receives a signal from sensors in the steering shaft that tells the motor to provide assistance to the steering gear. However, the steering wheel is still connected to the rack-and-pinion steering gear, just like in the hydraulic power steering system.

Towing

Towing Your Vehicle

Consult your dealer/retailer or a professional towing service if you need to have your disabled vehicle towed.

Recreational Vehicle Towing

Your vehicle is not designed to be towed with any of the wheels on the ground. If your vehicle must be towed, see *Towing Your Vehicle on page 4-2*.

Towing a Trailer

For more information, see “Towing a Trailer” in your owner manual Index.

Weight of the Trailer

How heavy can a trailer safely be?

It depends on how you plan to use your rig. For example, speed, altitude, road grades, outside temperature and how much your vehicle is used to pull a trailer are all important. And, it can also depend on any special equipment that you have on your vehicle.

Maximum trailer weight is calculated assuming the driver only is in the tow vehicle and it has all the required trailering equipment. The weight of additional optional equipment, passengers and cargo in the tow vehicle must be subtracted from the maximum trailer weight.

Use the following charts to determine how much your vehicle can weigh, based upon your vehicle model and options.

Vehicle	Axle Ratio	Maximum Trailer Weight	*GCWR
2WD 6.0 L V8	3.08	6,200 lbs (2 812 kg)	12,000 lbs (5 443 kg)
4WD 6.0 L V8	3.08	6,000 lbs (2 721 kg)	12,000 lbs (5 443 kg)

*The Gross Combination Weight Rating (GCWR) is the total allowable weight of the completely loaded vehicle and trailer including any passengers, cargo, equipment and conversions. The GCWR for your vehicle should not be exceeded.

Trailer Brakes

If you are towing a trailer that is equipped with trailer brakes and you manually apply the trailer brakes while driving slower than 25 mph (40 km/h), your vehicle may go into auto stop mode even if you are not pressing on the vehicle's brakes. Using the trailer brake system manually can make your hybrid vehicle perform as if you are using the brake pedal in the vehicle.

The trailer brake operation check will still work. If you manually apply the trailer brakes for an extended period of time, the SERVICE BRAKE SYSTEM DIC message will come on. The message will go off after the trailer brakes have been released. No other action is necessary. For more information, see "Trailer Brakes" in the Index of the vehicle's owner manual.

Section 5 Service and Appearance Care

Service	5-2	Bulb Replacement	5-21
Doing Your Own Service Work	5-2	Taillamps, Turn Signal, Stoplamps and Back-up Lamps	5-21
Checking Things Under the Hood	5-3	Replacement Bulbs	5-22
High Voltage Devices and Wiring	5-3	Electrical System	5-22
Engine Compartment Overview	5-4	Fuses and Circuit Breakers	5-22
Automatic Transmission Fluid	5-5	Underhood Fuse Block	5-22
Drive Motor/Generator Control Module (DMCM) Coolant Surge	5-5	Tires	5-24
Tank Pressure Cap	5-6	Inflation - Tire Pressure	5-24
Drive Motor/Generator Control Module (DMCM) Cooling System	5-6	Tire Pressure Monitor Operation	5-25
Power Steering Fluid	5-11	Tire Inspection and Rotation	5-28
Brakes	5-11	Tire Chains	5-30
Battery	5-14	If a Tire Goes Flat	5-30
Jump Starting	5-16	Tire Sealant and Compressor Kit	5-31
		Capacities and Specifications	5-42

Service

Doing Your Own Service Work

CAUTION:

Never try to do your own service on hybrid components. You can be injured and your vehicle can be damaged if you try to do your own service work. Service and repair of these hybrid components should only be performed by a trained service technician with the proper knowledge and tools.

CAUTION:

You can be injured and your vehicle could be damaged if you try to do service work on a vehicle without knowing enough about it.

- Be sure you have sufficient knowledge, experience, the proper replacement parts, and tools before you attempt any vehicle maintenance task.
- Be sure to use the proper nuts, bolts, and other fasteners. English and metric fasteners can be easily confused. If you use the wrong fasteners, parts can later break or fall off. You could be hurt.

If you want to do some of your own service work, you should use the proper service manual. It tells you much more about how to service your vehicle than this manual can. To order the proper service manual, see “Service Publications Ordering Information” in the owner manual.

Your vehicle has an airbag system. Before attempting to do your own service work, see “Servicing Your Airbag-Equipped Vehicle” in the owner manual.

You should keep a record with all parts receipts and list the mileage and the date of any service work you perform. See “Maintenance Record” in the owner manual.

Checking Things Under the Hood

High Voltage Devices and Wiring

CAUTION:

Exposure to high voltage can cause shock, burns, and even death. The high voltage systems in your vehicle can only be serviced by technicians with special training.

High voltage devices are identified by labels. Do not remove, open, take apart, or modify these devices. High voltage cable or wiring has orange covering. Do not probe, tamper with, cut, or modify high voltage cable or wiring.

Engine Compartment Overview

When you open the hood on your vehicle, you will see:

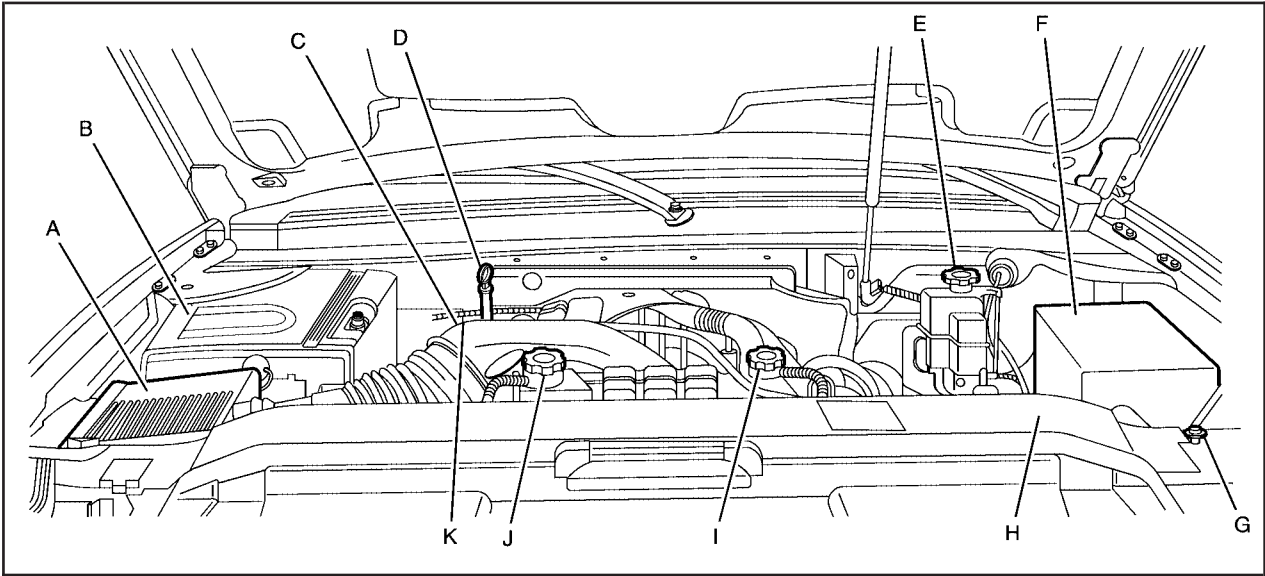

- A. Engine Air Cleaner/Filter. See “Engine Air Cleaner/Filter” in the owner manual Index.
- B. Drive Motor/Generator Control Module (DMCM). See *Drive Motor/Generator Control Module (DMCM) Coolant Surge Tank Pressure Cap on page 5-6*.
- C. Engine Oil Dipstick. See “Engine Oil” in the owner manual Index.
- D. Automatic Transmission Fluid Dipstick. See *Automatic Transmission Fluid on page 5-5*.
- E. Brake Fluid Reservoir. See *Brakes on page 5-11*.
- F. Underhood Fuse Block. See “Underhood Fuse Block” in the owner manual Index.
- G. Windshield Washer Fluid Reservoir. See “Windshield Washer Fluid” in the owner manual Index.
- H. Hybrid Auxiliary Fuse Block. See *Underhood Fuse Block on page 5-22*.
- I. DMCM Coolant Surge Tank Pressure Cap. See *Drive Motor/Generator Control Module (DMCM) Coolant Surge Tank Pressure Cap on page 5-6*.
- J. Engine Coolant Surge Tank Pressure Cap. See “Coolant Surge Tank Pressure Cap” in the owner manual Index.
- K. Engine Oil Fill Cap (Out of View). See “Engine Oil” in the owner manual Index.

Automatic Transmission Fluid

For more information, see “Automatic Transmission Fluid” in the owner manual Index.

Checking the Fluid Level

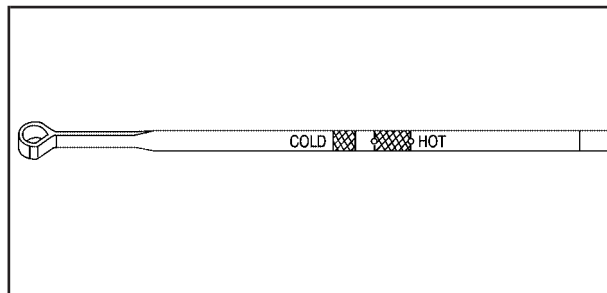

Your vehicle’s automatic transmission dipstick looks like this. For more information on location, see *Engine Compartment Overview on page 5-4*.

Drive Motor/Generator Control Module (DMCM) Coolant Surge Tank Pressure Cap

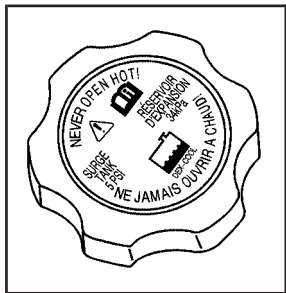

See *Engine Compartment Overview* on page 5-4 for more information on location.

The Drive Motor/Generator Control Module (DMCM) coolant surge tank pressure cap must be fully installed on the hybrid coolant surge tank.

Notice: If the pressure cap is not tightly installed, coolant loss and possible damage to the Drive Motor/Generator Control Module (DMCM) may occur. Be sure the cap is properly and tightly secured.

Drive Motor/Generator Control Module (DMCM) Cooling System

In addition to your vehicle's regular cooling system, your vehicle is also equipped with a cooling system for the DMCM system. This system is serviced differently than the vehicle's main cooling system. The DMCM cooling system includes the DMCM coolant surge tank, DMCM surge tank pressure cap, DMCM cooling pumps, hybrid cooling radiator and the Drive Motor/Generator Control Module (DMCM). The DMCM cooling system uses a 50/50 pre-mixed DEX-COOL™ coolant and deionized water available at your dealer/retailer, but the two systems operate separately and independently. See "Engine Coolant" and "Cooling System" in the Index of the owner's manual for more information.

When you decide it is safe to lift the hood, here is what you will see:

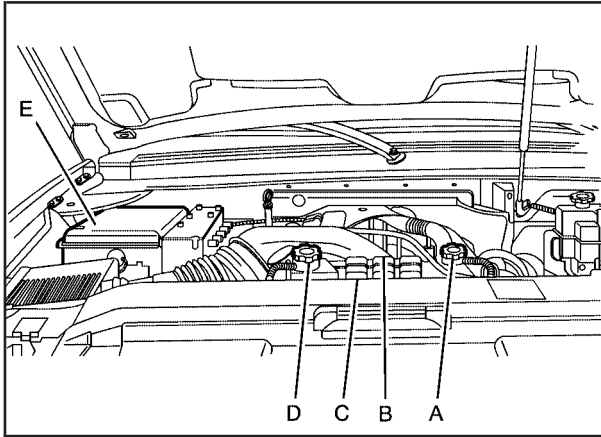

- | | |
|--|--|
| A. DMCM Coolant Tank Pressure Cap | D. Engine Coolant Surge Tank Pressure Cap |
| B. DMCM Cooling Hoses (Out of View) | E. Drive Motor/Generator Control Module (DMCM) |
| C. DMCM Coolant Surge Tank/Engine Coolant Surge Tank | |

If the coolant inside the DMCM coolant surge tank is boiling, do not do anything else until it cools down.

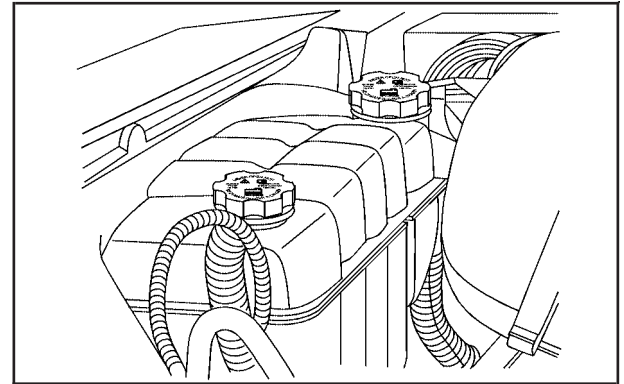

The coolant level should be at or above the FULL COLD mark with the vehicle parked on a level surface. If it is not, you may have a leak at the DMCM cooler core, DMCM pressure cap, DMCM cooler hoses, DMCM cooling pump or somewhere else in the DMCM cooling system.

Notice: Running the engine when there is a leak in the hybrid cooling system can cause the hybrid cooling system to lose all coolant and can damage the system. Get any leak fixed before you drive the vehicle or run the engine.

How to Add Coolant to the DMCM Coolant Surge Tank

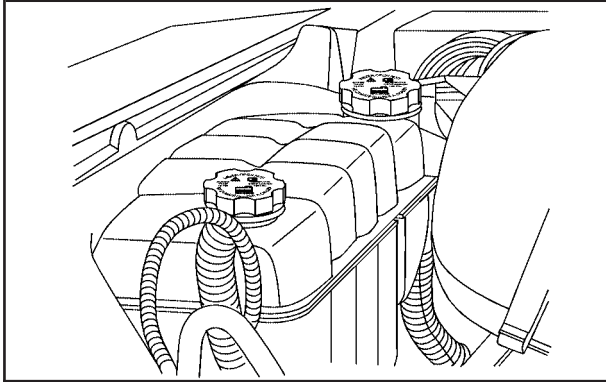

If you have not found a problem yet, check to see if coolant is visible in the DMCM coolant surge tank. If coolant is visible, add pre-mixed DEX-COOL™ coolant, available at your dealer/retailer, at the DMCM coolant surge tank, but be sure the DMCM cooling system, including the DMCM coolant surge tank pressure cap, is cool before you do it. Use the procedure following.

⚠ CAUTION:

Steam and scalding liquids from a hot cooling system can blow out and burn you badly. They are under pressure, and if you turn the coolant surge tank pressure cap — even a little — they can come out at high speed. Never turn the cap when the cooling system, including the coolant surge tank pressure cap, is hot. Wait for the cooling system and coolant surge tank pressure cap to cool if you ever have to turn the pressure cap.

Notice: Using coolant other than a pre-mixed DEX-COOL, available at your dealer/retailer, may damage your vehicle. Any repairs would not be covered by your warranty. Always use a pre-mixed DEX-COOL (silicate-free) coolant in your vehicle.

⚠ CAUTION:

You can be burned if you spill coolant on hot engine parts. Coolant contains ethylene glycol and it will burn if the engine parts are hot enough. Do not spill coolant on a hot engine.

If the DMCM coolant is empty, your vehicle must be serviced by your dealer and a special fill procedure must be followed.

Notice: Attempting to fill the DMCM cooling surge tank yourself when the fluid level is empty can damage your vehicle. Your vehicle must be serviced.

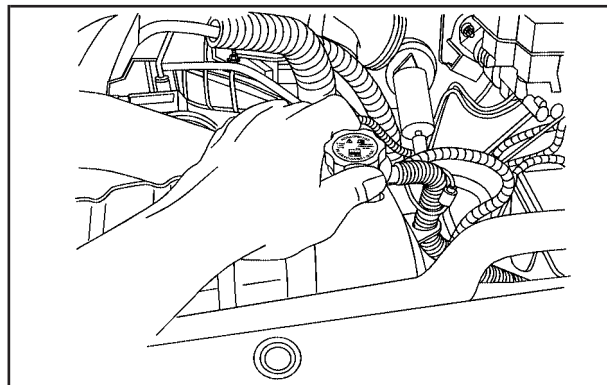

1. Park the vehicle on a level surface and turn the vehicle off. You can remove the DMCM coolant surge tank pressure cap when the DMCM cooling system, including the DMCM coolant surge tank pressure cap and DMCM cooling hoses, are no longer hot. Turn the DMCM coolant surge tank pressure cap slowly counterclockwise (left) about one full turn. Wait 30 seconds.

Power Steering Fluid

Your vehicle has electric power steering and does not use power steering fluid.

Brakes

Brake Fluid

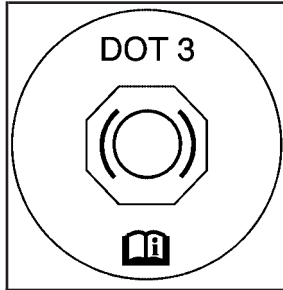

The brake master cylinder reservoir is filled with DOT-3 brake fluid. See *Engine Compartment Overview* on page 5-4 for the location of the reservoir.

There are only two reasons why the brake fluid level in the reservoir might go down. The first is that the brake fluid goes down to an acceptable level during normal brake lining wear. When new linings are put in, the fluid level goes back up. The other reason is that fluid is leaking out of the brake hydraulic system. If it is, have the brake hydraulic system fixed, since a leak means that sooner or later the brakes will not work well.

It is not a good idea to top off the brake fluid. Adding brake fluid will not correct a leak. If fluid is added when the linings are worn, there will be too much fluid when new brake linings are installed. Add or remove brake fluid, as necessary, only when work is done on the brake hydraulic system.

CAUTION:

If you have too much brake fluid, it can spill on the engine. The fluid will burn if the engine is hot enough. You or others could be burned, and your vehicle could be damaged. Add brake fluid only when work is done on the brake hydraulic system. See “Checking Brake Fluid” in this section.

When the brake fluid falls to a low level, the brake warning light will come on. See “Brake System Warning Light” in the owner manual.

Refer to the Maintenance Schedule to determine when to check the brake fluid. See “Scheduled Maintenance” in the owner manual.

Checking Brake Fluid

The brake fluid can be checked without taking off the cap by looking at the brake fluid reservoir.

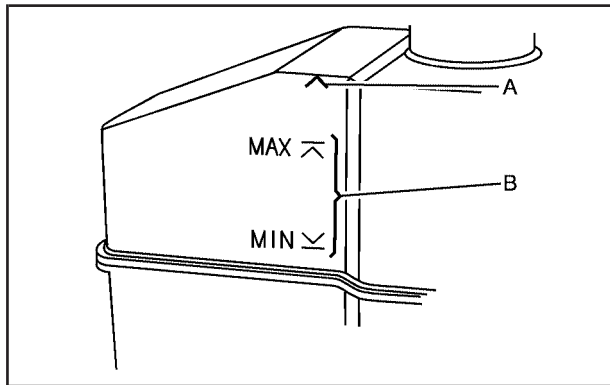

With the engine not running for at least one minute, the maximum fluid level (A) is at the top of the reservoir body. With the engine running, the fluid level should be in the proper operating range (B) between the MIN and MAX marks. If it is not, have the brake hydraulic system checked to see if there is a leak.

After work is done on the brake hydraulic system, make sure the level, with the engine running, is in the proper operating range (B) between the MIN and MAX marks.

What to Add

When you do need brake fluid, use only DOT-3 brake fluid. Use new brake fluid from a sealed container only. See “Recommended Fluids and Lubricants” in the owner manual.

Always clean the brake fluid reservoir cap and the area around the cap before removing it. This helps keep dirt from entering the reservoir.

CAUTION:

With the wrong kind of fluid in the brake hydraulic system, the brakes might not work well. This could cause a crash. Always use the proper brake fluid.

Notice:

- Using the wrong fluid can badly damage brake hydraulic system parts. For example, just a few drops of mineral-based oil, such as engine oil, in the brake hydraulic system can damage brake hydraulic system parts so badly that they will have to be replaced. Do not let someone put in the wrong kind of fluid.
- If you spill brake fluid on your vehicle's painted surfaces, the paint finish can be damaged. Be careful not to spill brake fluid on your vehicle. If you do, wash it off immediately. See "Washing Your Vehicle" in the owner manual.

Brake Wear

Your vehicle has disc brakes. Disc brake pads have built-in wear indicators that make a high-pitched warning sound when the brake pads are worn and new pads are needed. The sound can come and go or be heard all the time your vehicle is moving, except when you are pushing on the brake pedal firmly.

CAUTION:

The brake wear warning sound means that soon the brakes will not work well. That could lead to an accident. When you hear the brake wear warning sound, have your vehicle serviced.

Notice: Continuing to drive with worn-out brake pads could result in costly brake repair.

Some driving conditions or climates can cause a brake squeal when the brakes are first applied or lightly applied. This does not mean something is wrong with the brakes.

Properly torqued wheel nuts are necessary to help prevent brake pulsation. When tires are rotated, inspect brake pads for wear and evenly tighten wheel nuts in the proper sequence to torque specifications in "Capacities and Specifications" in the owner manual.

Brake linings should always be replaced as complete axle sets.

Brake Pedal Travel

See your dealer/retailer if the brake pedal does not return to normal height, or if there is a rapid increase in pedal travel. This could be a sign that brake service might be required.

Brake Adjustment

Every time you make a brake stop, the disc brakes adjust for wear.

Replacing Brake System Parts

The braking system on a vehicle is complex. Its many parts have to be of top quality and work well together if the vehicle is to have really good braking. Your vehicle was designed and tested with top-quality brake parts. When you replace parts of the braking system — for example, when the brake linings wear down and you need new ones put in — be sure you get new approved replacement parts. If you do not, the brakes might not work properly. For example, if someone puts in brake linings that are wrong for your vehicle, the balance between the front and rear brakes can change — for the worse. The braking performance you have come to expect can change in many other ways if someone puts in the wrong replacement brake parts.

Battery

Your vehicle has a standard 12-volt battery and a high-voltage hybrid battery.

When it is time for a new standard 12-volt battery, see your dealer/retailer for one that has the replacement number shown on the original battery's label.

When it is time for a new high-voltage hybrid battery, see your dealer/retailer.

If an airbag inflates or the vehicle has been in a crash, the vehicle's sensing system may command the automatic hybrid battery disconnect to open. See *Replacing Restraint System Parts After a Crash on page 1-3* for more information.

Warning: Battery posts, terminals, and related accessories contain lead and lead compounds, chemicals known to the State of California to cause cancer and reproductive harm. Wash hands after handling.

Vehicle Storage

CAUTION:

Batteries have acid that can burn you and gas that can explode. You can be badly hurt if you are not careful. See *Jump Starting on page 5-16* for tips on working around a battery without getting hurt.

Infrequent Usage: If you drive your vehicle infrequently, remove the 12-volt battery black, negative (-) cable from the battery. This will help keep the battery from running down.

Extended Storage: For extended storage of your vehicle, remove the 12-volt battery black, negative (-) cable from the battery or use a battery trickle charger. This will help maintain the charge of the battery over an extended period of time.

Remember to reconnect the battery when you are ready to drive your vehicle.

Jump Starting

If the vehicle's battery (or batteries) have run down, you may want to use another vehicle and some jumper cables to start your vehicle. Use the following steps to do it safely.

CAUTION:

Batteries can hurt you. They can be dangerous because:

- They contain acid that can burn you.
- They contain gas that can explode or ignite.
- They contain enough electricity to burn you.

If you do not follow these steps exactly, some or all of these things can hurt you.

Notice: Ignoring these steps could result in costly damage to your vehicle that would not be covered by your warranty.

Trying to start your vehicle by pushing or pulling it will not work, and it could damage your vehicle.

1. Check the other vehicle. It must have a 12-volt battery with a negative ground system.

Notice: If the other vehicle's system is not a 12-volt system with a negative ground, both vehicles can be damaged. Only use vehicles with 12-volt systems with negative grounds to jump start your vehicle.

2. Get the vehicles close enough so the jumper cables can reach, but be sure the vehicles are not touching each other. It could cause a ground connection you do not want. You would not be able to start your vehicle, and the bad grounding could damage the electrical systems.

Notice: If you leave your radio or other accessories on during the jump starting procedure, they could be damaged. The repairs would not be covered by your warranty. Always turn off your radio and other accessories when jump starting your vehicle.

3. Turn off the ignition on both vehicles. Unplug unnecessary accessories plugged into the cigarette lighter or the accessory power outlets. Turn off the radio and all the lamps that are not needed. This avoids sparks and helps save both batteries. It could save the radio!
4. Open the hood on the other vehicle and locate the positive (+) and negative (-) terminal locations on that vehicle.

Your vehicle has a remote positive (+) and a remote negative (-) jump starting terminal. You should always use these remote terminals instead of the terminals on the battery.

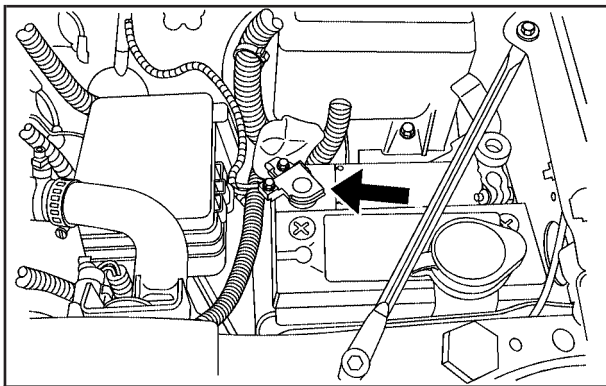

⚠ CAUTION:

An electric fan can start up even when the engine is not running and can injure you. Keep hands, clothing and tools away from any underhood electric fan.

If the vehicle has a remote positive (+), it is located under a red plastic cover at the positive battery post. To uncover the remote positive (+) terminal, open the red plastic cover.

5. The remote negative (-) is a solid engine ground.

CAUTION:

Using a match near a battery can cause battery gas to explode. People have been hurt doing this, and some have been blinded. Use a flashlight if you need more light.

Be sure the battery has enough water. You do not need to add water to the battery installed in your new vehicle. But if a battery has filler caps, be sure the right amount of fluid is there. If it is low, add water to take care of that first. If you do not, explosive gas could be present.

Battery fluid contains acid that can burn you. Do not get it on you. If you accidentally get it in your eyes or on your skin, flush the place with water and get medical help immediately.

CAUTION:

Fans or other moving engine parts can injure you badly. Keep your hands away from moving parts once the engine is running.

6. Check that the jumper cables do not have loose or missing insulation. If they do, you could get a shock. The vehicles could be damaged too.

Before you connect the cables, here are some basic things you should know. Positive (+) goes to positive (+) or to a remote positive (+) terminal if the vehicle has one. Negative (-) will go to a heavy, unpainted metal engine part or a solid engine ground.

Do not connect positive (+) to negative (-) or you will get a short that would damage the battery and maybe other parts too. Do not connect the negative (-) cable to the negative (-) terminal on the dead battery because this can cause sparks.

7. Connect the red positive (+) cable to the positive (+) terminal of the vehicle with the dead battery. Use a remote positive (+) if the vehicle has one.
8. Do not let the other end touch metal. Connect it to the positive (+) terminal of the good battery. Use a remote positive (+) if the vehicle has one.
9. Now connect the black negative (-) cable to the negative (-) terminal of the good battery. Use a remote negative (-) if the vehicle has one.

Do not let the other end touch anything until the next step. The other end of the negative (-) cable does not go to the dead battery. It goes to a heavy, unpainted metal engine part or to the remote negative (-) terminal on the vehicle with the dead battery.
10. Connect the other end of the negative (-) cable to the remote negative (-) terminal, on the vehicle with the dead battery.
11. Now start the vehicle with the good battery and run the engine for a while.
12. Try to start the vehicle that had the dead battery. If it will not start after a few tries, it probably needs service.

Notice: If the jumper cables are connected or removed in the wrong order, electrical shorting may occur and damage the vehicle. The repairs would not be covered by your warranty. Always connect and remove the jumper cables in the correct order, making sure that the cables do not touch each other or other metal.

Jumper Cable Removal

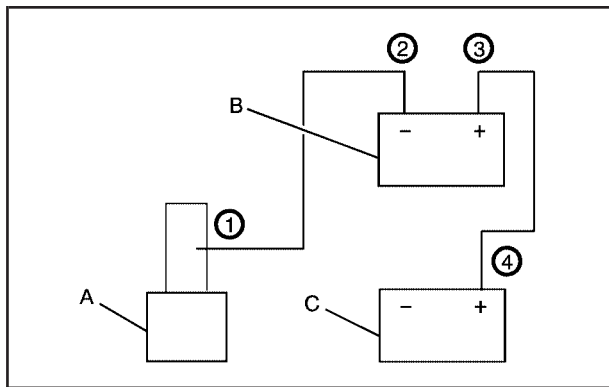

- A. Heavy, Unpainted Metal Engine Part or Remote Negative (-) Terminal
- B. Good Battery or Remote Positive (+) and Remote Negative (-) Terminals
- C. Dead Battery or Remote Positive (+) Terminal

To disconnect the jumper cables from both vehicles:

1. Disconnect the black negative (-) cable from the vehicle that had the bad battery.
2. Disconnect the black negative (-) cable from the vehicle with the good battery.
3. Disconnect the red positive (+) cable from the vehicle with the good battery.
4. Disconnect the red positive (+) cable from the other vehicle.
5. Return the remote positive (+) terminal cover to its original position.

Bulb Replacement

Taillamps, Turn Signal, Stoplamps and Back-up Lamps

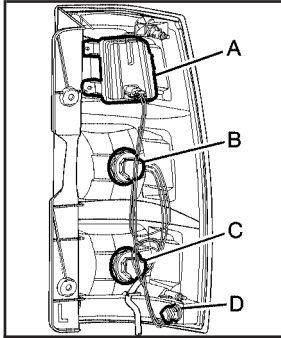

A. Taillamp/Stoplamp
B. Back-up Lamp

C. Turn Signal Lamp
D. Sidemarker Lamp

If the taillamp/stoplamp (A) need to be replaced, see your dealer/retailer.

1. Open the liftgate. See “Power Liftgate” in the owner’s manual index.

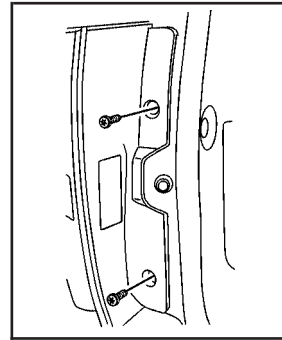

2. Remove the two screws from the taillamp assembly.
3. Pull the taillamp assembly rearward until the inner pins on the taillamp assembly are disengaged from the vehicle.
4. Press the release tab, if bulb socket has one, and turn the bulb socket counterclockwise to remove it from the taillamp assembly.
5. Pull the old bulb straight out from the bulb socket.
6. Press a new bulb into the bulb socket and insert it into the taillamp assembly. Turn the bulb socket clockwise into the taillamp assembly until it clicks.
7. Reinstall the taillamp assembly. When reinstalling, make sure to line up the pins on the taillamp assembly with the vehicle. If this is not done the taillamp assembly cannot be correctly installed.

Replacement Bulbs

Exterior Lamp	Bulb Number
Back-up Lamp and Rear Turn Signal Lamp	3156
Sidemarkers Lamp	194

For replacement bulbs not listed here, contact your dealer/retailer.

Electrical System

Fuses and Circuit Breakers

The wiring circuits in your vehicle are protected from short circuits by a combination of fuses, circuit breakers and fusible thermal links. This greatly reduces the chance of fires caused by electrical problems.

Be sure you replace a bad fuse with a new one of the identical size and rating.

If you ever have a problem on the road and do not have a spare fuse, you can borrow one that has the same amperage. Just pick some feature of your vehicle that you can get along without, like the radio or cigarette lighter, and use its fuse, if it is the correct amperage. Replace it as soon as you can.

Your vehicle also has a special fuse in the battery box for the 300-volt batteries. If this fuse has failed and needs to be replaced, the vehicle will be disabled and you will need to have your vehicle repaired by your dealer/retailer. Do not attempt to self-service this fuse.

Underhood Fuse Block

Hybrid Auxiliary Underhood Fuse Block

The hybrid underhood fuse block is located in the engine compartment near the front of the vehicle. Lift the cover for access to the fuse/relay block. See *Engine Compartment Overview on page 5-4* for more information on its location. For more information on the main underhood fuse block, see "Underhood Fuse Block" in the owner manual Index.

To remove fuses, hold the end of the fuse between your thumb and index finger and pull straight out.

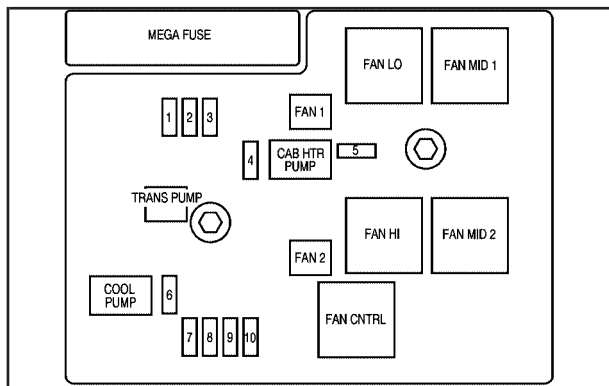

Fuses	Usage
1	ACPO
2	BECM FAN
3	ACCM
4	CAB HTR PMP
5	EMPTY
6	COOL PUMP
7	EPS

Fuses	Usage
8	Drive Motor/Generator Control Module 1
9	Drive Motor/Generator Control Module 2
10	BECM

J-Case	Usage
FAN 1	Cooling Fan 1
TRANS PUMP	Auxiliary Transmission Fluid Pump
FAN 2	Cooling Fan 2
CAB HTR PMP	Cab Heater Pump

Relays	Usage
FAN LOW	Cooling Fan Low Speed Relay
FAN MID 1	Cooling Fan Mid 1
FAN HI	Cooling Fan High Speed Relay
FAN MID 2	Cooling Fan Mid 2
FAN CNTRL	Cooling Fan Control

Tires

Inflation - Tire Pressure

Tires need the correct amount of air pressure to operate effectively.

Notice: Do not let anyone tell you that under-inflation or over-inflation is all right. It is not. If your tires do not have enough air (under-inflation), you can get the following:

- Too much flexing
- Too much heat
- Tire overloading
- Premature or irregular wear
- Poor handling
- Reduced fuel economy

If your tires have too much air (over-inflation), you can get the following:

- Unusual wear
- Poor handling
- Rough ride
- Needless damage from road hazards

A vehicle specific Tire and Loading Information label is attached to your vehicle. This label shows your vehicle's original equipment tires and the correct inflation pressures for your tires when they are cold. The recommended cold tire inflation pressure, shown on the label, is the minimum amount of air pressure needed to support your vehicle's maximum load carrying capacity.

For additional information regarding how much weight your vehicle can carry, and an example of the Tire and Loading Information label, see "Loading Your Vehicle" in the Index of the owner manual. How you load your vehicle affects vehicle handling and ride comfort. Never load your vehicle with more weight than it was designed to carry.

When to Check

Check your tires once a month or more.

How to Check

Use a good quality pocket-type gage to check tire pressure. You cannot tell if your tires are properly inflated simply by looking at them. Radial tires may look properly inflated even when they're underinflated. Check the tire's inflation pressure when the tires are cold. Cold means your vehicle has been sitting for at least three hours or driven no more than 1 mile (1.6 km).

Remove the valve cap from the tire valve stem. Press the tire gage firmly onto the valve to get a pressure measurement. If the cold tire inflation pressure matches the recommended pressure on the tire and loading information label, no further adjustment is necessary. If the pressure is low, add air until you reach the recommended amount.

If you overfill the tire, release air by pushing on the metal stem in the center of the tire valve. Recheck the tire pressure with the tire gage.

Be sure to put the valve caps back on the valve stems. They help prevent leaks by keeping out dirt and moisture.

Tire Pressure Monitor Operation

The Tire Pressure Monitor System (TPMS) is designed to warn the driver when a low tire pressure condition exists. TPMS sensors are mounted onto each tire and wheel assembly. The TPMS sensors monitor the air pressure in the vehicle's tires and transmit the tire pressure readings to a receiver located in the vehicle.

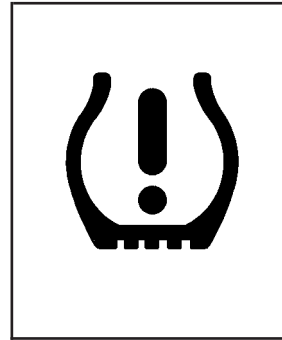

When a low tire pressure condition is detected, the TPMS will illuminate the low tire pressure warning symbol located on the instrument panel cluster.

At the same time a message to check the pressure in a specific tire appears on the Driver Information Center (DIC) display. The low tire pressure warning light and the DIC warning message come on at each ignition cycle until the tires are inflated to the correct inflation pressure. Using the DIC, tire pressure levels can be viewed by the driver. For additional information and details about the DIC operation and displays see *DIC Warnings and Messages on page 3-11*. Also, see “DIC Operation and Displays” in the Index of the owner manual for more information.

The low tire pressure warning light may come on in cool weather when the vehicle is first started, and then turn off as you start to drive. This could be an early indicator that the air pressure in the tire(s) are getting low and need to be inflated to the proper pressure.

A Tire and Loading Information label, attached to your vehicle, shows the size of your vehicle's original equipment tires and the correct inflation pressure for your vehicle's tires when they are cold. See "Loading Your Vehicle" for an example of the Tire and Loading Information label and its location on your vehicle. Also see *Inflation - Tire Pressure on page 5-24*.

Your vehicle's TPMS can warn you about a low tire pressure condition but it does not replace normal tire maintenance. See "Tire Inspection and Rotation" and "Tires" in the Index of the owner manual for more information.

Notice: Using non-approved tire sealants could damage the Tire Pressure Monitor System (TPMS) sensors. TPMS sensor damage caused by using an incorrect tire sealant is not covered by the vehicle warranty. Always use the GM approved tire sealant available through your dealer/retailer.

Your vehicle, when new, included a factory-installed Tire Sealant and Compressor Kit. This kit uses a GM approved liquid tire sealant. See *Tire Sealant and Compressor Kit on page 5-31*.

TPMS Malfunction Light and Message

The TPMS will not function properly if one or more of the TPMS sensors are missing or inoperable. When the system detects a malfunction, the low tire warning light flashes for about one minute and then stays on for the remainder of the ignition cycle. A DIC warning message is also displayed. The low tire warning light and DIC warning message come on at each ignition cycle until the problem is corrected. Some of the conditions that can cause the malfunction light and DIC message to come on are:

- The TPMS sensor matching process was started but not completed or not completed successfully after rotating the vehicle's tires. The DIC message and TPMS malfunction light should go off once the TPMS sensor matching process is performed successfully. See "TPMS Sensor Matching Process" later in this section.
- One or more TPMS sensors are missing or damaged. The DIC message and the TPMS malfunction light should go off when the TPMS sensors are installed and the sensor matching process is performed successfully. See your dealer/retailer for service.

- Replacement tires or wheels do not match your vehicle's original equipment tires or wheels. Tires and wheels other than those recommended for your vehicle could prevent the TPMS from functioning properly. See "Buying New Tires" in the Index of the owner manual.
- Operating electronic devices or being near facilities using radio wave frequencies similar to the TPMS could cause the TPMS sensors to malfunction.

If the TPMS is not functioning it cannot detect or signal a low tire condition. See your dealer/retailer for service if the TPMS malfunction light and DIC message comes on and stays on.

TPMS Sensor Matching Process

Each TPMS sensor has a unique identification code. Any time you rotate your vehicle's tires or replace one or more of the TPMS sensors, the identification codes will need to be matched to the new tire/wheel position. The sensors are matched to the tire/wheel positions in the following order: driver side front tire, passenger side front tire, passenger side rear tire, and driver side rear tire using a TPMS diagnostic tool. See your dealer/retailer for service.

The TPMS sensors can also be matched to each tire/wheel position by increasing or decreasing the tire's air pressure. If increasing the tire's air pressure, do not exceed the maximum inflation pressure indicated on the tire's sidewall.

To decrease air-pressure out of a tire you can use the pointed end of the valve cap, a pencil-style air pressure gage, or a key.

You have two minutes to match the first tire/wheel position, and five minutes overall to match all four tire/wheel positions. If it takes longer than two minutes, to match the first tire and wheel, or more than five minutes to match all four tire and wheel positions the matching process stops and you need to start over.

The TPMS sensor matching process is outlined below:

1. Set the parking brake.
2. Turn the ignition switch to ON/RUN with the engine off.
3. Press the Remote Keyless Entry (RKE) transmitter's LOCK and UNLOCK buttons at the same time for approximately five seconds. The horn sounds twice to signal the receiver is in relearn mode and TIRE LEARNING ACTIVE message displays on the DIC screen.
4. Start with the driver side front tire.
5. Remove the valve cap from the valve cap stem. Activate the TPMS sensor by increasing or decreasing the tire's air pressure for five seconds, or until a horn chirp sounds. The horn chirp, which may take up to 30 seconds to sound, confirms that the sensor identification code has been matched to this tire and wheel position.

6. Proceed to the passenger side front tire, and repeat the procedure in Step 5.
7. Proceed to the passenger side rear tire, and repeat the procedure in Step 5.
8. Proceed to the driver side rear tire, and repeat the procedure in Step 5. The horn sounds two times to indicate the sensor identification code has been matched to the driver side rear tire, and the TPMS sensor matching process is no longer active. The TIRE LEARNING ACTIVE message on the DIC display screen goes off.
9. Turn the ignition switch to LOCK/OFF.
10. Set all four tires to the recommended air pressure level as indicated on the Tire and Loading Information label.
11. Put the valve caps back on the valve stems.

Tire Inspection and Rotation

Tires should be rotated every 5,000 to 8,000 miles (8 000 to 13 000 km).

Any time you notice unusual wear, rotate your tires as soon as possible and check wheel alignment. Also check for damaged tires or wheels. See “When It Is Time for New Tires” and “Wheel Replacement” in the Index of the owner manual for more information.

The purpose of regular rotation is to achieve more uniform wear for all tires on the vehicle. The first rotation is the most important. See “Scheduled Maintenance” in the Index of the owner manual.

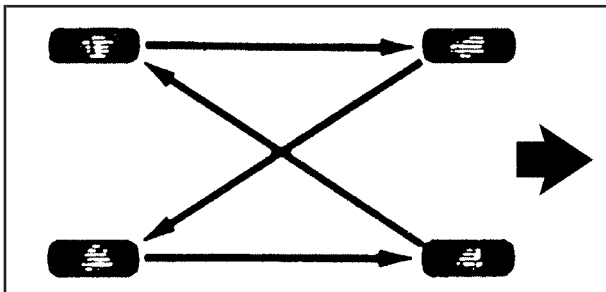

When rotating your tires, always use the correct rotation pattern shown here.

After the tires have been rotated, adjust the front and rear inflation pressures as shown on the Tire and Loading Information label. See “Loading Your Vehicle” in the Index of the owner manual for an example of the label and its location on your vehicle.

The Tire Pressure Monitor System (TPMS) sensors will need to be reset after a tire rotation. See “TPMS Sensor Identification Codes” under “Tire Pressure Monitor Operation”.

Make certain that all wheel nuts are properly tightened. See “Wheel Nut Torque” under “Capacities and Specifications” in the Index of the owner manual.

Tire Chains

CAUTION:

Do not use tire chains. There is not enough clearance. Tire chains used on a vehicle without the proper amount of clearance can cause damage to the brakes, suspension, or other vehicle parts. The area damaged by the tire chains could cause you to lose control of your vehicle and you or others may be injured in a crash. Use another type of traction device only if its manufacturer recommends it for use on your vehicle and tire size combination and road conditions. Follow that manufacturer's instructions. To help avoid damage to your vehicle, drive slowly, re-adjust or remove the device if it is contacting your vehicle, and do not spin your wheels. If you do find traction devices that will fit, install them on the rear tires.

If a Tire Goes Flat

Your vehicle has a tire inflator kit. There is no spare tire, no tire changing equipment, and no place to store a tire.

It is unusual for a tire to blow out while you are driving, especially if you maintain your tires properly. If air goes out of a tire, it is much more likely to leak out slowly. But, if you should ever have a blow out, here are a few tips about what to expect and what to do:

If a front tire fails, the flat tire creates a drag that pulls the vehicle toward that side. Take your foot off the accelerator pedal and grip the steering wheel firmly. Steer to maintain lane position, and then gently brake to a stop well out of the traffic lane.

A rear blow out, particularly on a curve, acts much like a skid and may require the same correction you would use in a skid. In any rear blow out, remove your foot from the accelerator pedal. Get the vehicle under control by steering the way you want the vehicle to go. It may be very bumpy and noisy, but you can still steer. Gently brake to a stop, well off the road if possible.

If a tire goes flat, avoid further tire and wheel damage by driving slowly to a level place and stopping. Then do this:

1. Turn on the hazard warning flashers.
2. Park your vehicle. Set the parking brake firmly and put the shift lever in PARK (P).
3. Turn off the engine.
4. Inspect the flat tire.

If the tire has been separated from the wheel or has damaged sidewalls or large tears that allow rapid air loss, call a tire repair facility. See “Roadside Assistance Program” in the Index of the owner manual.

If the flat tire is due to a slow leak caused by a nail or other similar road hazard, the tire inflator kit may be used to repair the damaged tire temporarily. The kit uses a liquid tire sealant to seal small punctures in the tread area of the tire.

After repairing a tire with the tire inflator kit, take your vehicle to an authorized retailer to have the tire inspected and repaired as soon as possible. The tire sealant is a temporary repair only. See *Tire Sealant and Compressor Kit on page 5-31*.

Tire Sealant and Compressor Kit

Your vehicle is equipped with a tire sealant and compressor kit that is capable of temporarily sealing a puncture up to 6 mm in the tread area of the tire. There is no jack or spare tire. The kit inflates the tire with liquid sealant and air. The tire sealant and compressor kit can also be used to inflate an underinflated tire. After the tire is inflated to the recommended pressure, see *Inflation - Tire Pressure on page 5-24*, the vehicle must be driven for five miles (8 kilometers) to distribute the sealant in the tire and seal the puncture. After driving five miles (8 kilometers), the tire pressure must be rechecked and adjusted as needed. See “Using the Tire Sealant and Compressor Kit to Temporarily Seal and Inflate a Punctured Tire” later in this section.

After temporarily repairing a tire using the tire sealant and compressor kit, take your vehicle to an authorized dealer/retailer as soon as possible. If the sealant is removed from the tire within 100 miles (161 kilometers) of driving, then it is easier to clean from the tire and you are less likely to require a replacement tire.

Be sure to read and follow all of the tire sealant and compressor kit instructions. The kit includes:

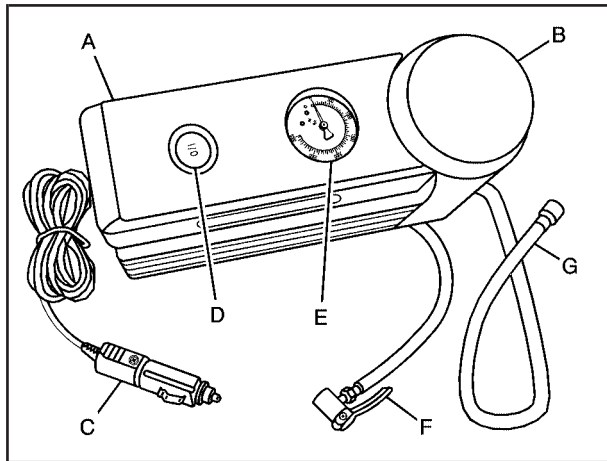

- | | |
|-------------------------------------|----------------------|
| A. Air Compressor | D. On/Off Switch |
| B. Tire Sealant Canister | E. Air Pressure Gage |
| C. Air Compressor
Accessory Plug | F. Air Only Hose |
| | G. Sealant/Air Hose |

Accessing the Tire Sealant and Compressor Kit

The tire sealant and compressor kit is located under the storage tray, which is located on the driver side trim panel (over the rear wheelhouse). To access the tire sealant and compressor kit:

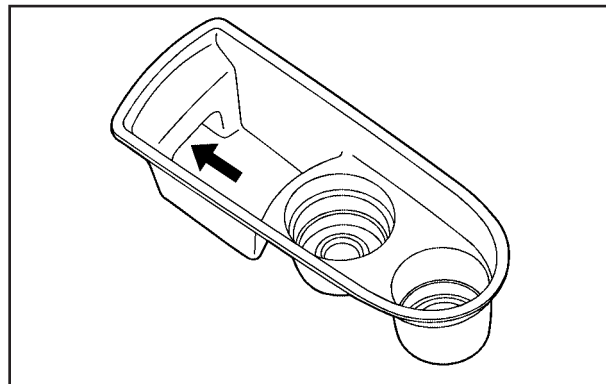

1. Remove the tray by pulling up on the finger depression to access the tire sealant and compressor kit.

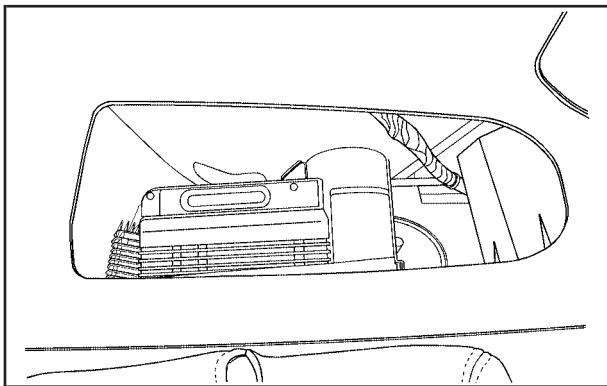

2. Locate the tire sealant and compressor kit.
3. Remove the sealant and compressor kit by pulling the velcro strip up and back to release it.
4. Remove the sealant and compressor kit from its plastic tray assembly.

Tire Sealant

When using the tire sealant and compressor kit during cold weather, warm the tire sealant and compressor kit in a heated environment such as the vehicle for five minutes. This will help to inflate your tire faster.

Read and follow the safe handling instructions on the instructional label adhered to the sealant canister.

Check the tire sealant expiration date on the sealant canister. The sealant canister should be replaced before its expiration date. Replacement canisters are available at your local dealer/retailer. See “Removal and Installation of Sealant Canister” later in this section.

The sealant can temporarily seal a puncture up to 6 mm in the tread area of the tire. The sealant cannot seal sidewall damage, large punctures, or a tire that has unseated from the wheel. See “Roadside Assistance Information” in the owner manual.

The sealant can only be used to seal one tire. After usage the tire sealant canister and sealant/air hose assembly must be replaced at a dealer/retailer. See “Removal and Installation of Sealant Canister” later in this section.

Using the Tire Sealant and Compressor Kit to Temporarily Seal and Inflate a Punctured Tire

Follow these directions closely for correct sealant usage.

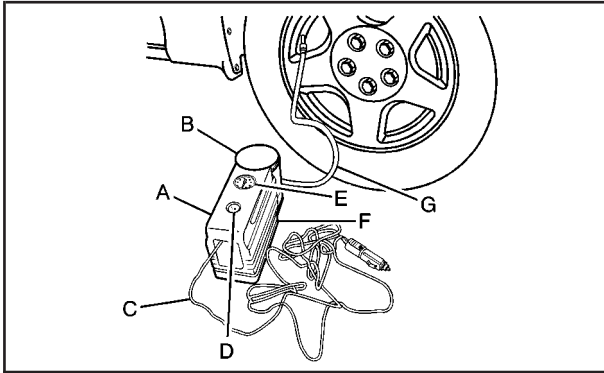

1. Do a safety check before proceeding. See *If a Tire Goes Flat on page 5-30*.
2. Inspect the damaged tire.
The sealant cannot seal sidewall damage, large punctures, or a tire that has unseated from the wheel. See "Roadside Assistance Program" in the owners manual.
Do not remove any objects that have penetrated the tire.

3. Place the tire sealant and compressor kit (A) on the ground and unwrap the sealant/air hose (G) from the side of the compressor.
4. Remove the valve stem cap from the flat tire by turning it counterclockwise.
5. Attach the sealant/air hose (G) onto the tire valve stem. Turn it clockwise until it is tight.
Make sure the sealant and compressor kit On/Off switch (D) is in the O (off) position.
6. Remove the air compressor accessory plug (C) from the unit.
7. Plug the air compressor accessory plug (C) into an accessory power outlet in the vehicle. See "Accessory Power Outlet" in the owner manual.
Do not slam the door or close the window on the air compressor accessory plug cord.

⚠ CAUTION:

Idling the engine in a closed-in place or with the climate control system off can cause deadly carbon monoxide (CO). See "Engine Exhaust" in the owner manual.

8. Start the vehicle. See *Starting Your Vehicle on page 2-3*. The vehicle must be running while using the air compressor.

 **CAUTION:**

Overinflation could cause the tire to rupture, and you or others could be injured. Be sure to read the inflator instructions, and inflate the tire to its recommended pressure. Do not exceed 36 psi (248 kPa).

9. Push the On/Off (D) to the I (on) position.
The tire sealant and compressor kit will inject sealant and air into the tire.
The pressure gage (E) will initially show a high pressure while the compressor pushes the sealant into the tire. Once the sealant is completely dispersed into the tire, the pressure will quickly drop and start to rise again as the tire inflates with air only.
10. Inflate the tire to the recommended inflation pressure using the air pressure gage (E) on the top of the unit. The recommended pressure can be found on the Tire Loading Information. See *Inflation - Tire Pressure on page 5-24*.

The pressure gage reading is slightly high while the compressor is on. Turn the compressor off to get an accurate pressure reading. The compressor may be turned on and off until the correct pressure is reached.

Notice: If the recommended pressure cannot be reached after approximately 25 minutes, the vehicle should not be driven farther. The tire is too severely damaged and the tire sealant and compressor kit cannot inflate the tire. Remove the air compressor plug from the accessory power outlet and unscrew the inflating hose from the tire valve. See “Roadside Assistance Program” in the owner manual.

11. Turn the compressor off by pushing the On/Off (D) button to the I (off) position.
Steps 12 through 20 must be done right after Step 11.
The tire is not sealed and will continue to leak air until the vehicle is driven and the sealant is distributed in the tire.
Be careful while handling the tire inflator components as they could be hot after usage.
12. Unplug the air compressor accessory plug (C) from the accessory power outlet in the vehicle.
13. Disconnect the sealant/air hose (G) from the tire valve stem, by turning it counterclockwise, and replace the tire valve stem cap.

14. Wrap the sealant/air hose (G) around the air compressor channel to stow it in its original location.
15. Stow the air compressor accessory plug (C) back in the air compressor. To do this, wrap the air compressor accessory plug, snap in the plug, and then push in the bottom and then the top of the wrapped air compressor accessory plug.

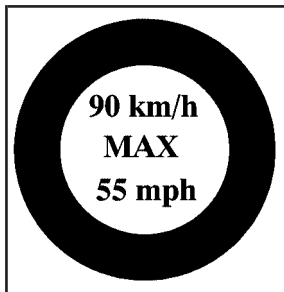

16. If the flat tire was able to be inflated to the recommended inflation pressure, remove the maximum speed label from the sealant canister (B).

17. Place it in a highly visible location such as the inside of the upper left corner of the windshield or to the face of the radio/clock.

The maximum speed label reminds you to drive cautiously and not to exceed 55 mph (90 km/h) until the damaged tire is inspected and repaired.

⚠ CAUTION:

Storing the tire sealant and compressor kit or other equipment in the passenger compartment of the vehicle could cause injury. In a sudden stop or collision, loose equipment could strike someone. Store the tire sealant and compressor kit in its original location.

18. Return the equipment to its original storage location in your vehicle.
19. Immediately drive the vehicle 5 miles (8 km) to distribute the sealant evenly in the tire.
20. Stop at a safe location and check the tire pressure, refer to Steps 1 through 11 under “Using the Tire Sealant and Compressor Kit without Sealant to Inflate an Underinflated Tire (Not Punctured)” later in this section.

If the tire pressure has fallen more than 10 psi (68 kPa), below the recommended inflation pressure, stop driving the vehicle. The tire is too severely damaged and the tire sealant and compressor kit cannot seal the tire. See “Roadside Assistance Program” in the owner manual.

If the tire pressure has not dropped more than 10 psi (68 kPa) from the recommended inflation pressure, inflate the tire back up to the recommended inflation pressure.

21. Wipe off any sealant from the wheel, tire, and vehicle.
22. Dispose of the sealant canister (B) and sealant air hose (G) at a local dealer/retailer or in accordance with your local state codes and practices.
23. After temporarily sealing a tire with the tire sealant and compressor kit, take your vehicle to an authorized dealer/retailer to have the tire repaired or replaced.

Using the Tire Sealant and Compressor Kit without Sealant to Inflate an Underinflated Tire (Not Punctured)

To use the air compressor to inflate a tire with air only and not sealant:

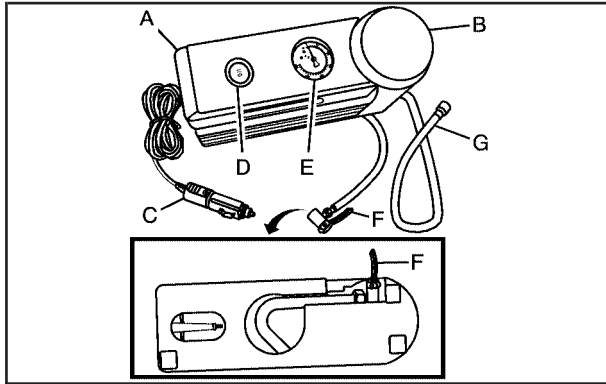

1. Unlock the air only hose (F) from the sealant canister (B) by pulling up on the lever.
2. Pull the air only hose (F) from the sealant canister (B).
3. Remove the tire valve stem cap from the flat tire by turning it counterclockwise.

4. Push the air only hose (F) onto the tire valve stem and push the lever down to secure in place.
5. Remove the air compressor accessory plug (C) from the unit.
6. Plug the air compressor accessory plug (C) into an accessory power outlet in the vehicle. See "Accessory Power Outlet" in the owner manual.
Do not slam the door or close the window on the compressor accessory plug cord.

⚠ CAUTION:

Idling the engine in a closed-in place or with the climate control system off can cause deadly carbon monoxide (CO). See "Engine Exhaust" in the owner manual.

7. Start the vehicle. See *Starting Your Vehicle on page 2-3*. The vehicle must be running while using the air compressor.

 **CAUTION:**

Overinflation could cause the tire to rupture, and you or others could be injured. Be sure to read the inflator instructions, and inflate the tire to its recommended pressure. Do not exceed 36 psi (248 kPa).

8. Push the On/Off switch (D) to the I (on) position.

The tire sealant and compressor kit will inflate the tire with air only.

9. Inflate the tire to the recommended inflation pressure using the air pressure gage (E) on the top of the unit.

The air pressure gage reads high while the compressor is on. Turn the compressor off to get an accurate reading. The compressor may be turned on and off until the correct pressure is reached. See *Inflation - Tire Pressure on page 5-24*.

10. Turn off the air compressor by pushing the On/Off switch (D) to the O (off) position.

Be careful while handling the tire sealant and compressor kit as they could be hot after usage.

11. Unplug the air compressor accessory plug (C) from the accessory power outlet in the vehicle.
12. Unlock the air only hose (F) from the tire valve stem by pulling the lever up.
13. Disconnect the air only hose (F) from the tire valve stem and replace the tire valve stem cap.

14. Wrap the air only hose (F) around the side of the air compressor channel to stow it back into place in its original location.
15. Stow the air compressor accessory plug (C) back in the air compressor. To do this, wrap the air compressor accessory plug, snap in the plug, and then push in the bottom and then the top of the wrapped air compressor accessory plug.

⚠ CAUTION:

Storing the tire sealant and compressor kit or other equipment in the passenger compartment of the vehicle could cause injury. In a sudden stop or collision, loose equipment could strike someone. Store the tire sealant and compressor kit in its original location.

16. Return the equipment to its original storage location of your vehicle.

Removal and Installation of the Sealant Canister

To remove the sealant canister:

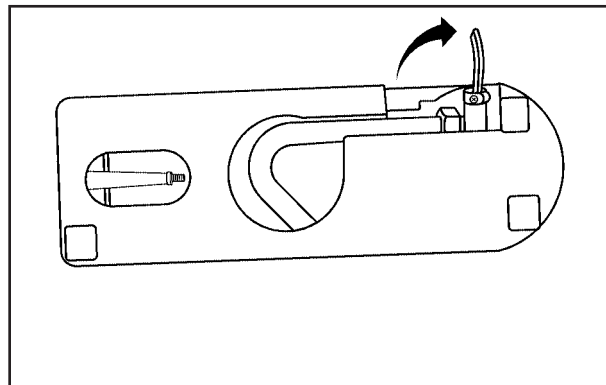

1. Unlock the air compressor inflating hose from the sealant canister by pulling up on the lever.
2. Pull the air only hose from the sealant canister.
3. Unwrap the sealant/air hose from the compressor.

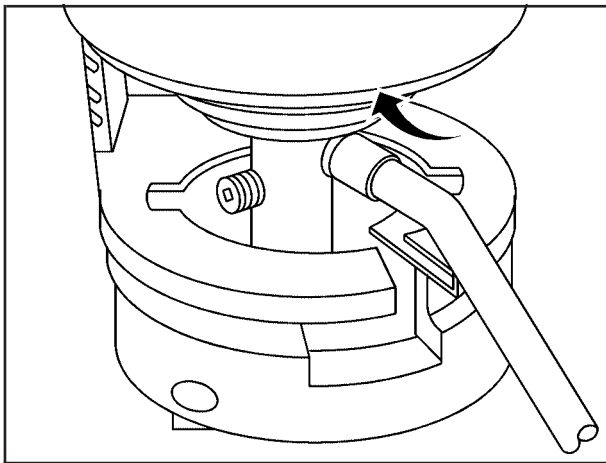

4. Turn the sealant canister so the inflator filling hose is aligned with the slot in the compressor.
5. Lift the sealant canister from the compressor.
6. Replace with a new sealant canister. See your dealer/retailer for the new sealant canister.

To install a new canister, do the following:

1. Align the sealant/air hose with the slot in the air compressor.
2. Push the sealant canister straight down and turn it clockwise.
3. Wrap the sealant/air hose around the air compressor channel to stow it in its original location.
4. Push the air only hose onto the sealant canister inlet and push the lever down to secure.

Capacities and Specifications

Application	Capacities	
	English	Metric
Cooling System		
Drive Motor Generator Control Module Cooling System	2.9 qt	2.7 L
6.0L V8 Engine Cooling System	15.5 qt	14.7 L
Fuel Tank	24.5 gal	92.7 L
All capacities are approximate. Recheck fluid level after filling.		

Section 6 Maintenance Schedule

Maintenance Schedule	6-2
Recommended Fluids and Lubricants	6-2
Engine Drive Belt Routing	6-2

Maintenance Schedule

Recommended Fluids and Lubricants

Fluids identified below are specific to the hybrid vehicle and can be obtained from your dealer/retailer. See the owner manual for the other fluids and lubricants recommended for the vehicle.

Usage	Fluid/Lubricant
Drive Motor/Generator Control Module (DMCM) Cooling System	Always use the pre-mixed 50/50 mixture of de-ionized water and DEX-COOL (silicate-free) coolant available at your dealer/retailer. See <i>Drive Motor/Generator Control Module (DMCM) Cooling System on page 5-6.</i>

Engine Drive Belt Routing

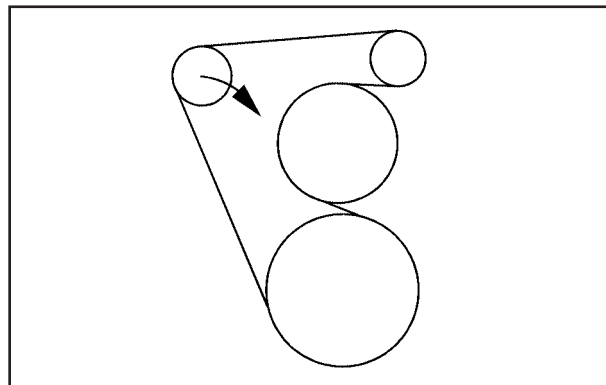

A

Alternating Current	
Power Outlet	2-2
Anti-lock Brake, System Warning Light	3-6
Audio System(s)	
Navigation/Radio System	3-13
Automatic Transmission	
Operation	2-6
Automatic Transmission, Fluid	5-5

B

Battery	5-14
Brakes	5-11
Regenerative Braking	2-9
Bulb Replacement	
Taillamps, Turn Signal, Stoplamps and Back-up Lamps	5-21

C

Capacities and Specifications	5-42
Chains, Tire	5-30
Charging System Light	3-4

Climate Controls	3-2
Compressor Kit, Tire Sealant	5-31
Coolant	
Engine Temperature Gage	3-7
Coolant Surge Tank Pressure Cap, (DMCM)	5-6
Cooling System, (DMCM)	5-6

D

Drive Motor/Generator Control Module (DMCM)	
Coolant Surge Tank Pressure Cap	5-6
Drive Motor/Generator Control Module (DMCM)	
Cooling System	5-6
Driver Information Center (DIC)	3-11
Warnings and Messages	3-11

E

Electric Power Steering	4-2
Engine	
Compartment Overview	5-4
Coolant Temperature Gage	3-7
Drive Belt Routing	6-2

F

Flat Tire	5-30
Fluid, Power Steering	5-11
Fuel	
Gage	3-10
Fuel Economy Gage	3-5
Fuse Block, Underhood	5-22
Fuses and Circuit Breakers	5-22

G

Gage	
Engine Coolant Temperature	3-7
Fuel	3-10
Fuel Economy	3-5
Oil Pressure	3-8

H

High Voltage Devices and Wiring	5-3
---------------------------------------	-----

I

Inflation - Tire Pressure	5-24
Inflator Kit, Tire	5-31
Instrument Panel Cluster	3-3
Introduction	ii

J

Jump Starting	5-16
---------------------	------

L

Light	
Anti-lock Brake System (ABS) Warning	3-6
Charging System	3-4
Oil Pressure	3-9
StabiliTrak [®] Indicator	3-4, 3-7

M

Maintenance Schedule	
Recommended Fluids and Lubricants	6-2
Manual, How to Use	iv
Manual Lumbar	1-2
Manual Reclining Seatback	1-2

N

Navigation/Radio System	3-13
-------------------------------	------

O

Oil	
Pressure Light	3-9
Oil Pressure Gage	3-8
Orange Covered Wiring	5-3

P

Power	
Seat	1-2
Power Outlet Alternating Current	2-2
Power Steering Fluid	5-11

R

Radios	
Navigation/Radio System	3-13
Recommended Fluids and Lubricants	6-2
Recreational Vehicle Towing	4-2
Regenerative Braking	2-9
Restraint System Check	
Replacing Restraint System Parts After a Crash	1-3
Routing, Engine Drive Belt	6-2
Running the Vehicle While Parked	2-10

S

Seats	
Manual Lumbar	1-2
Manual Reclining Seatback	1-2
Power Seats	1-2
Service, Doing Your Own Work	5-2
Specifications, Capacities	5-42
StabiliTrak [®] Indicator Light	3-4, 3-7
Starting Your Vehicle	2-3
Steering, Electric Power	4-2

T

Taillamps	
Turn Signal, Stoplamps and Back-up Lamps	5-21
Tires	
Chains	5-30
If a Tire Goes Flat	5-30
Inflation, Pressure	5-24
Inspection and Rotation	5-28
Tire Sealant and Compressor Kit	5-31
Towing	
Recreational Vehicle	4-2
Towing Your Vehicle	4-2
Trailer	4-2
Transmission, Automatic Fluid	5-5
Transmission Operation, Automatic	2-6

U

Underhood Fuse Block	5-22
----------------------------	------

V

Vehicle	
Running While Parked	2-10
Voltage Devices, High and Wiring	5-3

W

Warranty Information	ii
Wiring, High Voltage Devices	5-3